



DOC0935 IRmadillo User Manual

ASM0627-10-Z-Cx-Ex-Gx-D3x

www.keit.co.uk
support@keit.co.uk

Table of Contents

1.	Safety	3
1.0.	General safety	3
1.1.	Lifting instructions	3
1.2.	Electrical safety.....	3
1.3.	Pressure and temperature limits	3
1.4.	Operating environment limits	4
2.	How to Power, Purge and Connect the IRmadillo.....	5
2.1.	Powering the IRmadillo	5
2.1.1.	Uninterruptible power supply (UPS)	5
2.1.2.	Power cable	5
2.2.	Purging the IRmadillo.....	6
2.3.	How to connect data communications.....	8
2.3.1.	Connecting to the internal controller.....	8
2.4.	Checking for warnings and checking the probe is clean	10
2.4.1.	Cleaning instructions.....	10
2.4.2.	Recognising if the probe is clean	11
2.5.	Taking a background	12
2.6.	Installation best practice.....	12
2.7.	Avoiding fouling	15
3.	Maintenance	17
3.0.	Service and support contacts.....	17
3.1.	Maintenance & support programme (MSP)	17
3.2.	Spectrum health.....	17
3.2.1.	Use at high temperature	18
3.2.2.	Emitter ageing.....	18
3.3.	Remote health check	19
4.	Components	20
4.0.	IRmadillo spectrometer	20
4.0.1.	Dust caps.....	22
4.1.	Controller specifications	22
4.2.	Storage conditions	22
5.	Accessories	23
5.0.	Sample cell - ASM1398	23
5.0.1.	Maintenance	23
5.0.2.	Cleaning	23
5.1.	Flow cell.....	24

5.1.1.	High flow cell - ASM1392.....	24
5.1.2.	Low flow cell - ASM1222.....	25
5.1.3.	Tri-port flow cell - ASM1101.....	27
5.1.4.	Safety	28
5.1.5.	Maintenance	28
5.1.6.	Cleaning	28
5.2.	Flanged probe.....	29
5.2.1.	Safety	29
5.2.2.	Installation	30
5.2.3.	Maintenance	32
5.3.	Port tube - ASM1487	32
5.3.1.	Safety	33
5.3.2.	Installation	33
5.4.	Port Flange - ASM1486	33
5.4.1.	Safety	34
5.4.2.	Installation	35
5.4.3.	Maintenance	35
5.5.	Cradle - ASM1453	36
5.5.1.	Safety	37
5.5.2.	Installation	37
5.5.3.	Maintenance	38
5.6.	Inclined Stand – ASM0916.....	38
5.6.1.	Safety	39
5.6.2.	Installation	39
5.7.	Ingold DN40.....	40
5.7.1.	Safety	40
5.7.2.	Installation	41
6.	Troubleshooting	42





1. SAFETY

“**WARNING**” refers to situations that could result in **personal injury**.

“**CAUTION**” refers to situations that could result in **equipment damage**.

Failure to follow the requirements below may lead to dangerous situations.





1.0. General safety

 WARNING	The spectrometer weighs ~18 kg; handle with care
 CAUTION	Do not operate outside the range of environmental or analyte conditions specified on the product label
 CAUTION	The probe is NOT a carry handle
 CAUTION	Do not open the spectrometer; it contains no user-serviceable parts

1.1. Lifting instructions

Lift the device using the lip around the lid or with hands underneath the base. Do not use the probe as a carry handle; this could cause damage. Users should risk assess manual handling and use lifting equipment if necessary.

1.2. Electrical safety

 WARNING	The electrical mains cable must be earthed and should include a 5A fuse with a means of isolating both live and neutral; obey local electrical safety codes
 WARNING	An additional earth connection is provided on the enclosure chassis using an M6 screw; use if required by local codes
 WARNING	Never disconnect the mains power connector when energised
 CAUTION	Residual current protection or ground fault interrupter devices are recommended

1.3. Pressure and temperature limits

The maximum pressure and temperature (ambient and analyte) limits for the device vary depending on the model and mechanical interface. Refer to the product label to confirm the limits.

Do not exceed the pressure limits on the product label as this could be dangerous and will invalidate the warranty. If in doubt, contact Keit for advice before installing the spectrometer.

1.4. Operating environment limits



The spectrometer is thermally stabilised and designed to operate indoors or outdoors under a variety of conditions and environments. Avoiding exposure to direct sunlight will help maintain this thermal stability.

Table 1 – Atmospheric requirements for electrical safety

Parameters	Value	Units
Pollution degree of intended environment	4	
Maximum installation altitude	3000	metres

Pollution degree of the environment refers to the level of contamination that the exterior of the device can cope with. Pollution degree 4 means that continuous conductivity from conductive dust, rain or other wet conditions will not cause *electrical safety* to be compromised.

Consideration should also be given to ventilation of the surrounding area when the system is being purged.

 CAUTION	Purging the device with dry nitrogen is recommended for optimum performance (Note: maximum inlet pressure of 1 barg with a flow rate 0.5 to 2 litre/min).
 WARNING	When purging with nitrogen, ensure there is adequate ventilation to prevent asphyxiation; an oxygen sensor is recommended.

2. HOW TO POWER, PURGE AND CONNECT THE IRMADILLO

2.1. Powering the IRmadillo

**NOTE****See Section 1 Safety prior to attempting installation.**

The spectrometer is normally supplied with a blunt-cut mains cable to be wired into your electrical supply. The instrument requires single-phase mains input and must be connected to a permanent earth (grounding) connection. A 5A fuse should be fitted in the live/hot supply connection.

The power supply needs to be fitted with a means of isolating both live and neutral by fitting a disconnecting switch or using a suitable circuit breaker that meets the requirements of IEC 60947-1 and IEC 60947-3. The switch must be located within easy reach of the instrument and must be marked as the disconnection device for the equipment. The disconnection device must not interrupt the earth connection.

The spectrometer is designed to operate over a wide range of voltages shown below in Table 2 - IRmadillo power specifications. If you plan to operate the spectrometer outside of these ranges, contact Keit for advice before powering up the instrument.

Table 2 - IRmadillo power specifications

Parameters	Value	Units
AC input voltage	100-240	V
AC input frequency	50/60	Hz
Mains supply fluctuations (% of Nominal Value)	±10	%
Power consumption	110 (max)	W
Overvoltage Category	CAT II	

2.1.1. Uninterruptible power supply (UPS)

To ensure a reliable supply of power to the IRmadillo, we strongly recommend use of an uninterruptible power supply (UPS). Contact support@keit.co.uk for further information.

2.1.2. Power cable

The power cable for the IRmadillo is a permanently connected flying lead passed through a cable gland; this is located at the rear of the spectrometer. The gland and cable must be sufficiently protected from loading and twisting. The cable should ideally be routed above ground to avoid accidental damage.

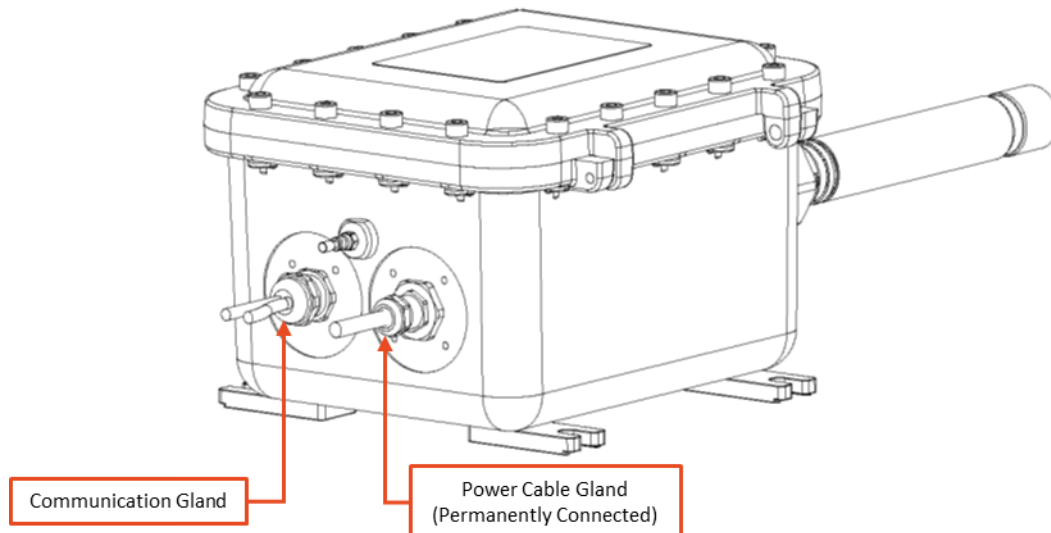

Figure 1: Power and communication gland locations for ASM0627-10-Z-Cx-Ex-Gx-D3x

The spectrometer body has an M6 earth attachment point below the probe. This can be used where local codes require it in addition to earthing through the power supply cable. Please identify and adhere to any applicable local standards.



WARNING

Failure to properly earth the spectrometer may cause serious injury or death.

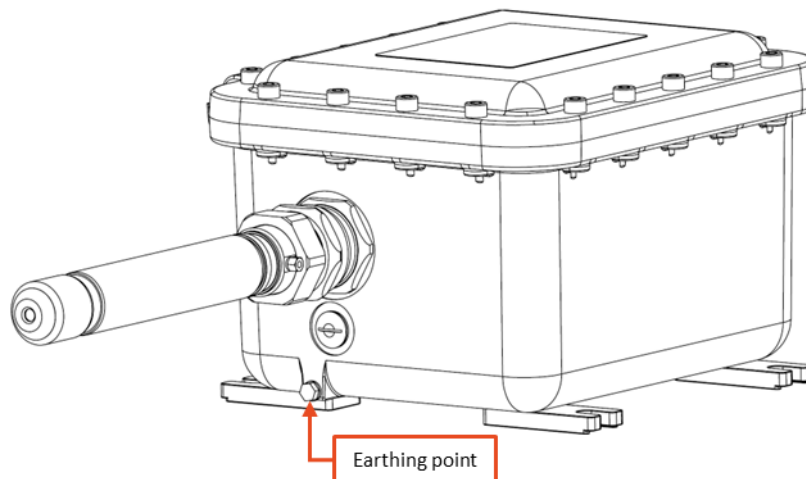

Figure 2: Earthing point for ASM0627-10-Z-Cx-Ex-Gx-D3x

2.2. Purging the IRmadillo

The IRmadillo spectrometer is designed to be continuously purged. This eliminates any interference in operation caused by changing levels of water vapour and carbon dioxide (CO₂) within the instrument, both of which interact strongly with infrared (IR) light.

The IRmadillo is fitted with a single body purge inlet and a breather in the probe. The Inlet is shipped with a blanking plug that needs to be removed before use.

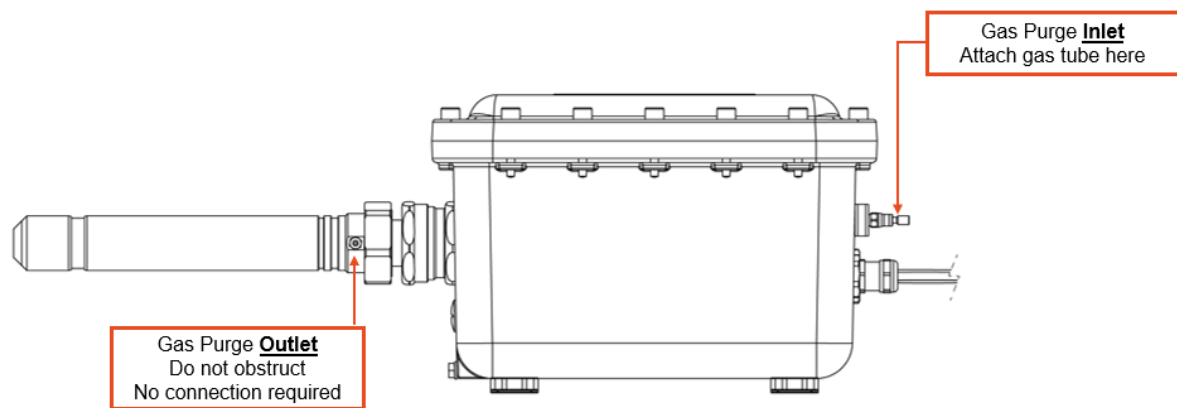



Figure 3: Purge inlet and outlet locations on ASM0627-10-Z-Cx-Ex-Gx-D3x

The ideal purge gas is dry nitrogen. Alternatively, dry air from a purge gas generator can be used. The output from this purge gas generator should have a minimum quality according to ISO8573-1:2010 of Class 1:2:1 (dust:water:oil) or better. Keit can recommend suitable generators that achieve this outlet air quality; contact support@keit.co.uk. Purge gas generators may include an internal compressor or use factory-supplied compressed air with a minimum quality of Class 4:4:4 (dust:water:oil).

	NOTE	<p>All FTIR spectrometers are very sensitive to water vapour and carbon dioxide. Even in well-controlled environments, e.g., laboratories, environmental changes can be large enough to cause significant changes in the spectrum. We STRONGLY recommend purging the instrument at all times.</p>
---	-------------	--

To purge the instrument:

- Connect a Ø 4 mm stainless steel or PTFE gas hose to the purge inlet. If using a single supply for multiple instruments, split with a manifold and flow regulator on each line.
- Set flow to (2.5 ± 0.5) L/min per instrument. For tubing lengths >50 m, set to (4 ± 0.5) L/min.
- Do not turn off purge during normal operation.
- If purge tubing is intentionally disconnected, fit blanking plug to maintain IP rating.
- The IRmadillo requires a stabilisation period of >12 hours once powered on and purging started.

Note: For instruments with gas outlet (Figure 17 Item D) option 2, the sintered 8 mm nut, set flow to 0.5 to 2 L/min for all tubing lengths.

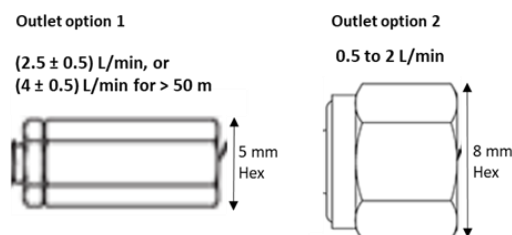



Figure 4: Purge outlet options

2.3. How to connect data communications

Like the power cable, the IRmadillo is supplied with dual flying leads for communication that are permanently connected through cable glands. You must ensure that the cables are sufficiently protected from loading and twisting. The cable should ideally be routed above ground to avoid accidental damage.

	NOTE	Ensure the mains and data communication cable connectors are dry prior to mating.
	NOTE	Keep the dust caps fitted on connectors when not in use. Never leave an exposed connector.

The communications flying leads provided with ASM0627-10-Z-Cx-Ex-Gx-D3x are Cat7 terminated in female RJ45 connectors. Either socket can be used to form a connection for DCS or access a network. For DCS guidance refer to the Modbus TCP commissioning guide (DOC0817) or OPC-UA commissioning guide (DOC0828); for copies contact support@keit.co.uk.

To connect, line up the latching surfaces and push together. This forms an IP67 rated connection. Standard RJ45 connectors can simply be plugged in but an IP rating cannot be guaranteed.



Figure 5: CNLinko LP16 RJ45 Plug



Figure 6: CNLinko LP16 RJ45 socket

2.3.1. Connecting to the internal controller

To set up the IRmadillo in preparation for install, remote access is needed. This is performed via Remote Desktop Connection from a local-access computer. A connection summary for Remote Desktop connection is available below. For a detailed access guide contact support@keit.co.uk.

The IRmadillo must be connected to the local-access computer either

- a) via a common network; or
- b) via a direct Ethernet-to-Ethernet connection

In the case of a), the network may need to be configured to allow Remote Desktop access between the local-access computer and the IRmadillo controller.

This section assumes that your local-access computer is running Microsoft Windows. However, we understand that Remote Desktop may be configured to work with a local-access computer running Linux, Mac OS or other non-Windows operating systems.

To connect to the instrument:

Once you have connected the IRmadillo controller using one of the above configurations, open Remote Desktop Connection on the local-access computer. This is normally located here:

Start Menu → Windows Accessories → Remote Desktop Connection

Alternatively, you can find it by pressing the **Windows** key (or **CTRL + ESC**), then typing *Remote Desktop Connection* and selecting the program when it appears. If you require frequent access, we recommend saving a convenient shortcut to this program.

You should be greeted with a window that looks like this. Click *Show Options*.

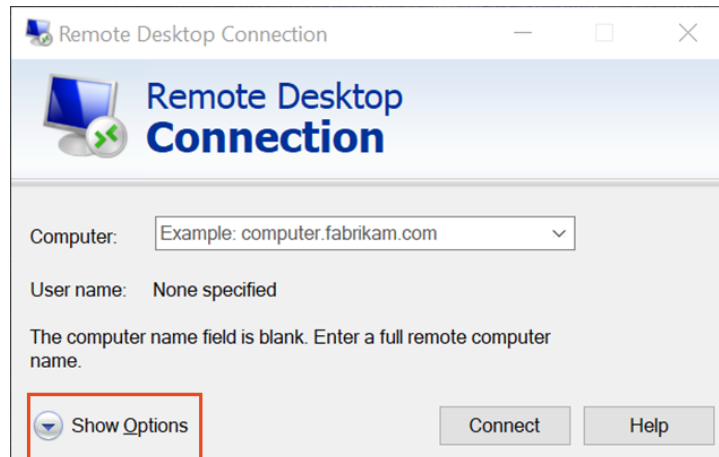

Figure 7: Remote Desktop Connection start window, Show Options highlighted in red

Access details are shared with you as part of the document pack and are unique for each individual IRmadillo. Contact support@keit.co.uk if unsure.

- Under *Computer*, you should enter the 'Name' of your computer.
- Under *Username*, enter the relevant account (*Spectrometer User* or *Administrator*).
- Click *Connect* and Windows will prompt you for a password. Enter the respective password and click *OK*.

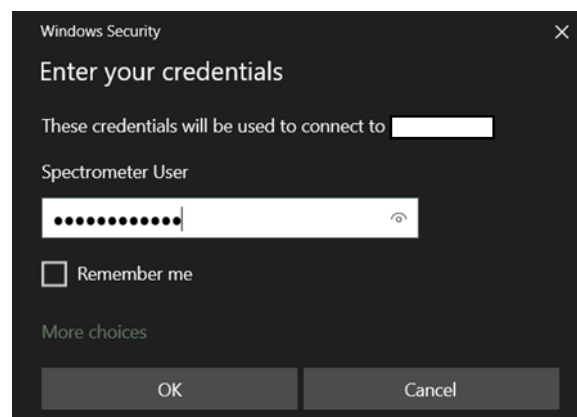

Figure 8: Login window

You should now have access to the relevant account.

2.4. Checking for warnings and checking the probe is clean

When you have connected to the powered-on IRmadillo the KeitSpec application should load automatically. It is important to confirm that the system is working without errors: information on IRmadillo warnings and errors can be found in DOC0893 KeitSpec Software User Manual section 1 Getting Started.

Once the system is set up without errors the probe tip must be cleaned, and a background spectrum must be taken before insertion into the vessel or pipe. If the probe is guaranteed clean the factory background scan shipped with the instrument – and saved to the desktop of the controller - can be used. Cleanliness of the probe tip is important to performance; if you suspect fouling or scale build-up, perform a clean appropriate to your environment.

2.4.1. Cleaning instructions

Rinse the ATR element with a suitable solvent. The choice of solvent will depend on your process. You may fully immerse the ATR in solvent if needed. The following are suitable:

- Water
- Acetone
- Alcohols
- Surfactant solutions
- Alkanes (hexane, cyclohexane etc...)
- Ethers

Once exposed to a suitable solvent wipe the ATR with a clean cloth. The metal tube of the probe can also be cleaned by wiping with a cloth.

For hard-to-remove fouling (such as biofilms or dried-on chemicals) Keit recommends an oxidative acid clean. First clean the ATR using the methods outlined above, then perform the following:

- Place the PTFE sample cell on the end of the probe and fill with ~4ml of 1 M nitric acid solution
- Leave to soak for 1 hr
- Carefully remove the acid using a pipette and fill the sample cell with water
- Remove the water using a pipette
- Remove the sample cell and rinse the ATR again with water
- Carefully wipe the ATR with a cloth

It may be necessary to repeat the cleaning steps again if the contaminant has only been partially removed.

In some cases, it may be necessary to perform an alkali clean on the probe. First clean the ATR using the methods outline above, then perform the following:

- Place the PTFE sample cell on the end of the probe and fill with ~4ml of 1 M sodium hydroxide solution
- Leave to soak for 1 hr
- Carefully remove the alkali using a pipette and fill the sample cell with water
- Remove the water using a pipette
- Remove the sample cell and rinse the ATR again with water
- Carefully wipe the ATR with a cloth

It may be necessary to repeat the cleaning steps again if the contaminant has only been partially removed.

2.4.2. Recognising if the probe is clean

When looking to see if the instrument is clean, the primary area of interest within the spectrum is between 800 and 1800 cm^{-1} . This section of the absorbance plot should maintain a relatively flat line with no consistently repeating peaks. Cleaning Mode can be used to see the effects of the cleaning process in real time – see DOC0893 KeitSpec Software User Manual Section 2 The Spectrometer Tab.

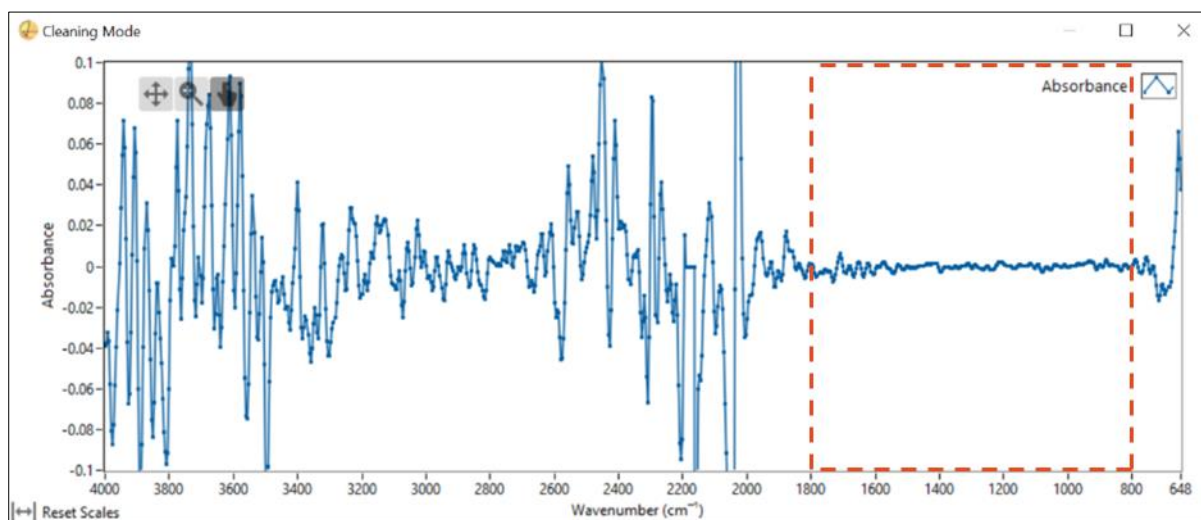

Figure 9: A clean probe showing no significant peaks within the 800 to 1800 cm^{-1} region.

Several sharp peaks in the region 800-1800 cm^{-1} indicate that the probe has not been cleaned properly.

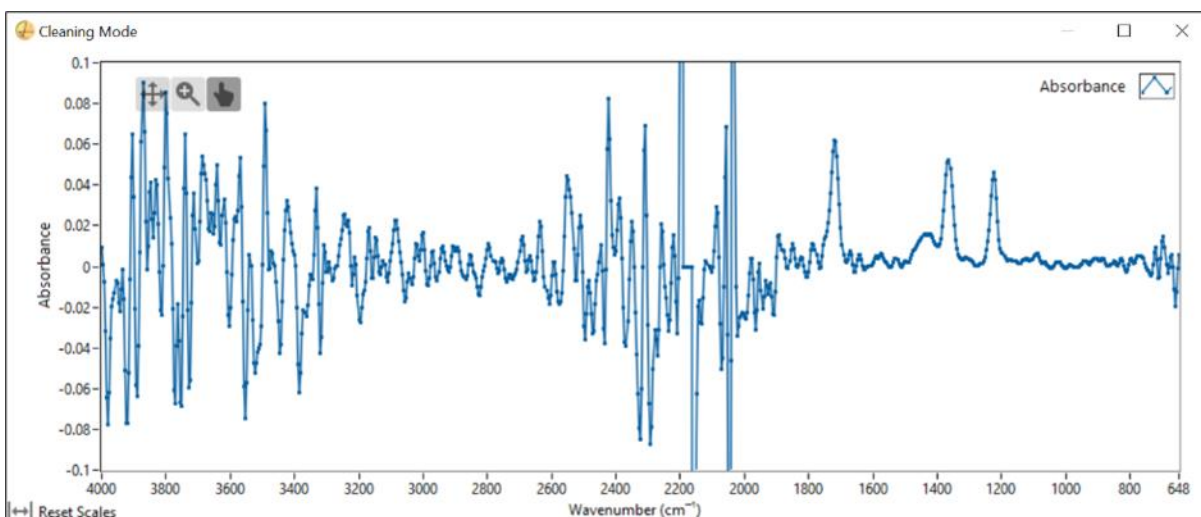

Figure 10: Sharp spikes within the region indicating an unclean probe

A peak at 1400 cm^{-1} indicates that there is some water on the probe. This could indicate poor purge quality.

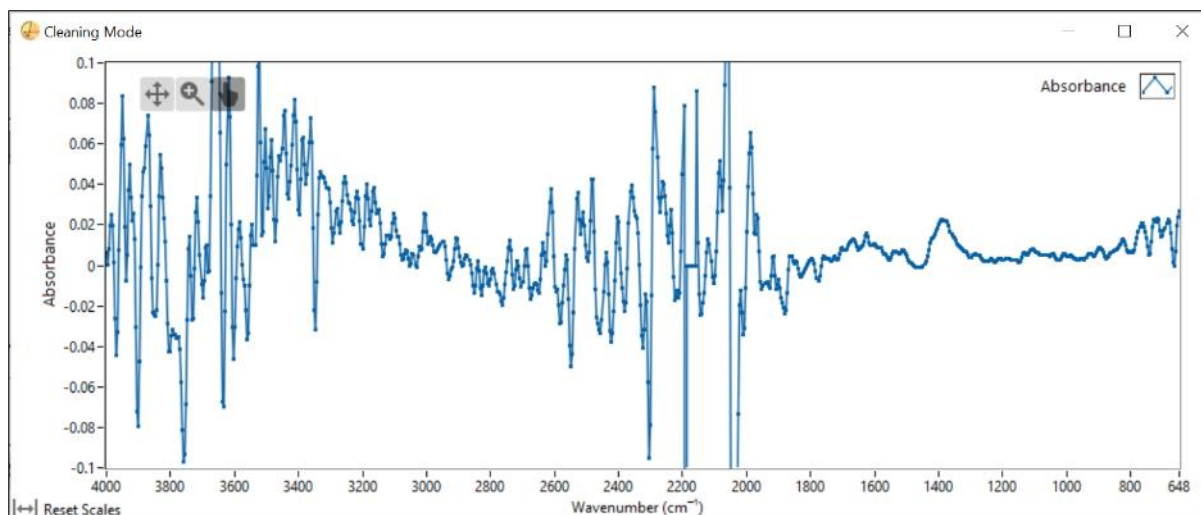

Figure 11: Peak indicating the water in the spectrum

A negative peak indicates that although the probe is clean now, it was not clean when the background was taken. Another background must be taken before any spectra can be measured.

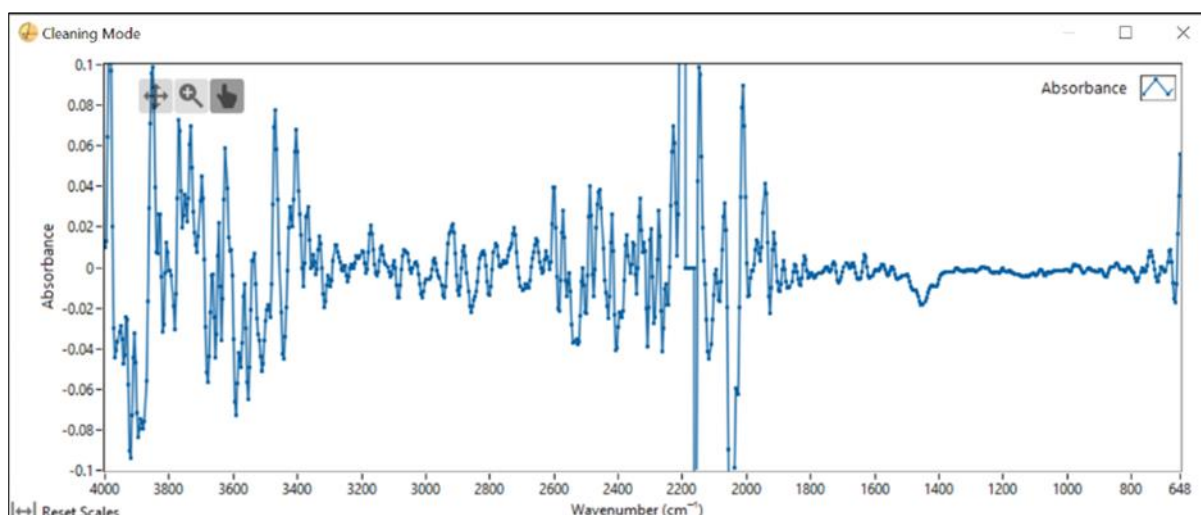

Figure 12: Negative peaks indicating the background was taken when the probe was unclean or not fully purged.

2.5. Taking a background

FTIR requires the collection of a background spectrum (also called a reference or baseline scan) before any absorption scans can be performed. This must be performed before the probe is inserted into the reaction/process of interest. The process for collecting a reference scan can be found in DOC0893 KeitSpec Software User Manual Section 1 Getting Started.

2.6. Installation best practice

Having cleaned the probe and taken a background spectrum, the IRmadillo is ready to be inserted into the reaction/process of interest.

Probe installation is unique for each application. Safe installation of the probe into the process is the responsibility of the user and should be assessed by a suitably trained person.

Please refer to the interface drawings of your probe and mounting system for further guidance. If you have not been provided with interface drawings, please contact support@keit.co.uk.

To ensure success with installs, it is important to consider the following requirements:

- The IRmadillo needs to be suitably supported. The weight of the instrument is ~18 kg, and it must be supported using the mounting points at the base, either through a custom stand or using a Keit Cradle. The probe should not be used to support the instrument.
- The body of the IRmadillo should not be placed in direct sunlight or near a heat source. The instrument has internal temperature control, but this rating is limited and model dependant. Direct heat sources can force the instrument beyond its operating range and cause damage.
- The IRmadillo must be axially restrained when in the flow. Pressure on the probe will cause the system to move if not properly restrained along the probe's axis.

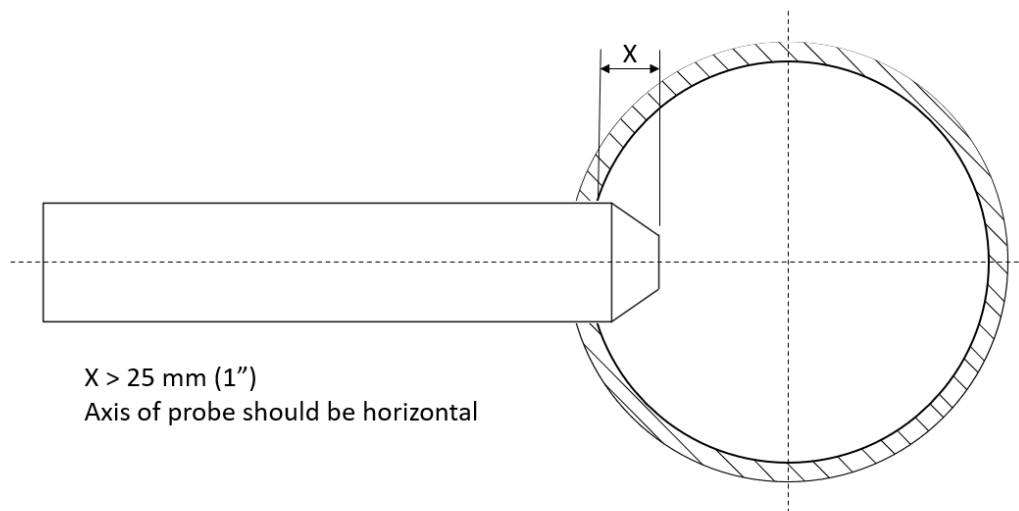

Figure 13 Probe immersion depth in pipework

- The central axis of the probe must be in line with the centre of the pipework.
- The probe must be aligned correctly with the port in which it is placed. It should not be forced or bent into place as this will cause damage to the instrument.
- The position of the probe end from the internal pipe wall is $> 25 \text{ mm (1")}$.
- The IRmadillo must be exposed to the flow when in operation. The probe tip must be positioned in the flow within the pipeline or vessel to perform correctly; turbulent flow is desired. If the tip is held in stagnant chemistry, building representative chemometric models will not be possible.
- It is preferable to mount the IRmadillo with the probe positioned horizontally. Mounting the IRmadillo with the probe pointing downwards risks the formation of bubbles on the

ATR element, and prevents the ATR from coming into full contact with the analyte to correctly analyse the process liquid.

- Similarly, avoid mounting the IRmadillo with the probe pointing upwards. If there are any suspended solids in the mixture, there is a risk of these solids settling on the probe tip, which may result in the spectra not being representative of the process liquid.
- The IRmadillo body should not be placed directly in caustic or acidic environments. The body is made from aluminium and will break down.
- To calibrate the IRmadillo, it is necessary to take samples from your process to analyse offline. The sampling point should be close to the IRmadillo's installation location to ensure that the sample that is taken is representative of the process fluid that is being measured by the IRmadillo at that time. See DOC0926 Offline sampling for IRmadillo calibration for more information on sampling.

2.7. Avoiding fouling

The diamond window at the tip of the probe must be in contact with process fluid in order to give a measurement. Even a thin layer of scaling or fouling will prevent the IRmadillo from being able to 'see' the process fluid.

To minimise the risk of fouling of the diamond window, we recommend taking the following steps during installation:

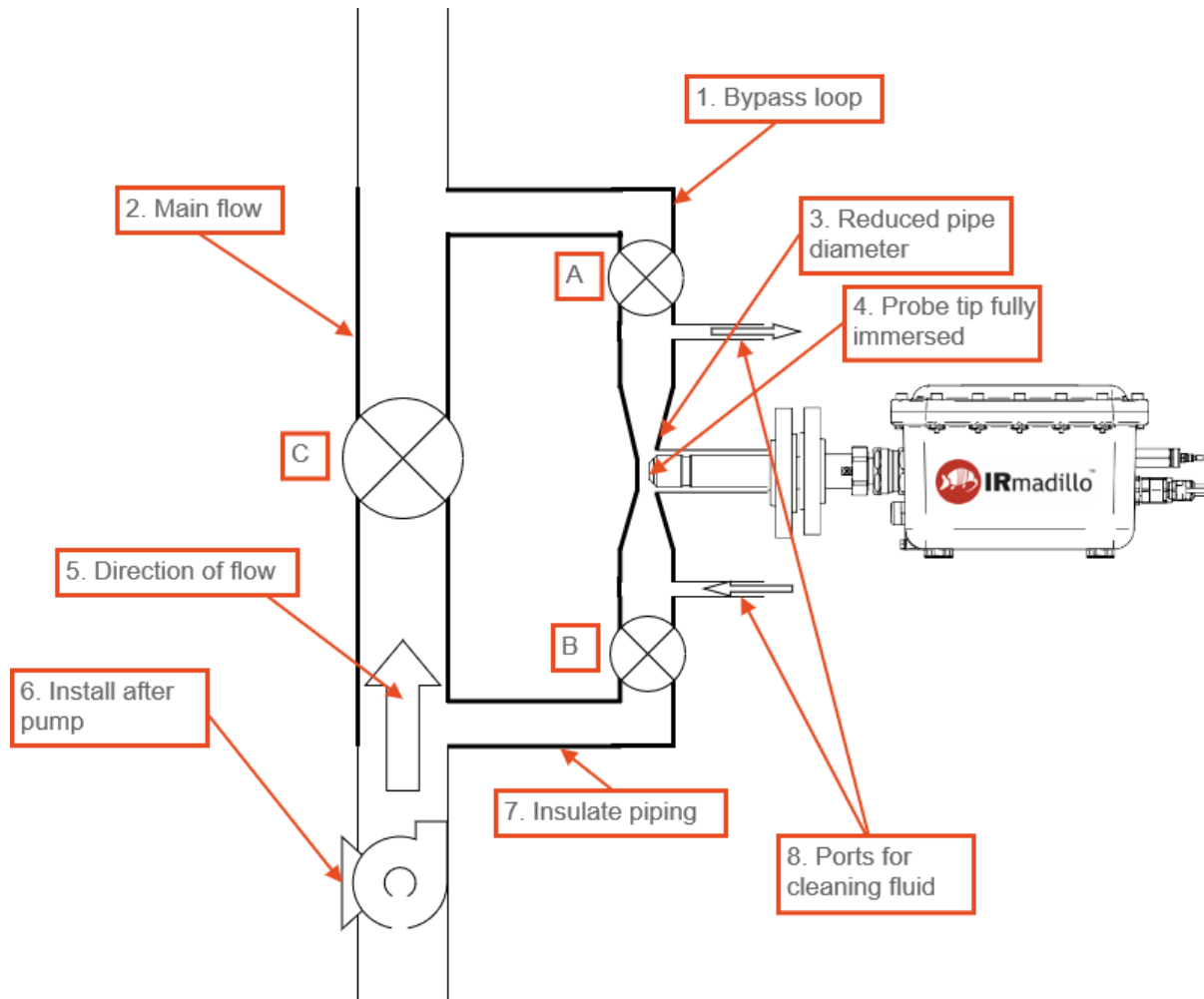

Figure 14: Installing the IRmadillo in a fouling environment

1. Particularly for continuous processes, install the IRmadillo in a bypass loop which can be isolated using valves A and B. This makes it easy to retract the IRmadillo for manual cleaning if required without the need to interrupt the process flow.
2. Direct the flow through the IRmadillo's bypass loop by blocking or restricting the 'main' flow unless the bypass loop is to be isolated (valve C). Alternatively, this may be achieved by mounting in a pump bypass loop (offtake from pump discharge and return to pump suction).
3. Maximise the flow velocity past the IRmadillo by installing in a reduced-diameter section of the pipe. The minimum flow velocity should be 1.5 m/s (5 ft/s), unless there is a risk of abrasion. If so contact Keit to discuss installation.
4. Install the IRmadillo so that the probe tip is fully in the flow. We recommend putting the probe tip as close to the centre of the pipe as possible.

5. The direction of flow should be vertically upwards. This both minimises the risk of air bubbles becoming trapped around the probe tip, and reduces the risk of settling of any sediment that is present.
6. To increase the pressure, install the IRmadillo after a pump. Higher pressure minimises the risk of sedimentation and bubbles.
7. Where possible, install the IRmadillo at a location where the process conditions are less prone to fouling. Depending on your process chemistry, this may be achieved by choosing a high temperature location and using heat tracing and insulation to avoid localised cooling. Higher process temperatures often maximise the solubility of potential fouling substances.
8. Fit ports either side of the IRmadillo's install point to allow clean-in-place or flushing with a suitable cleaning fluid.

3. MAINTENANCE

There are no user-serviceable parts inside the IRmadillo. Please contact Keit or our local agent to arrange service or repair. Service should only be performed by suitably trained engineers.

Probe accessories may contain O-rings, which we recommend replacing annually or, where worn or damaged, more frequently. See Section 5 Accessories for more information on accessories.

3.0. Service and support contacts

Website: www.keit.co.uk

Postal address: Keit Ltd.
Unit 4, Zephyr Building
Eighth Street, Harwell Campus
Didcot
Oxfordshire
OX11 0RL
United Kingdom

Telephone number: +44 (0) 1235 431260

Support email: support@keit.co.uk

3.1. Maintenance & support programme (MSP)

The MSP is for those customers who purchase an IRmadillo and want the assurance that their instrument will receive regular system maintenance to operate smoothly and uninterrupted. The service package provides a comprehensive set of health checks, upgrades and remote support to keep the IRmadillo functioning at the highest level.

It is desirable for Keit to have remote access to the Spectrometer User account on the controller in order to provide remote support. If this is not possible, issues may require the system to be returned to Keit for diagnosis.

For more information about our maintenance & support programme contact Keit using enquiries@keit.co.uk.

3.2. Spectrum health

The spectrum can be used as a good indication of the health of the instrument.

3.2.1. Use at high temperature

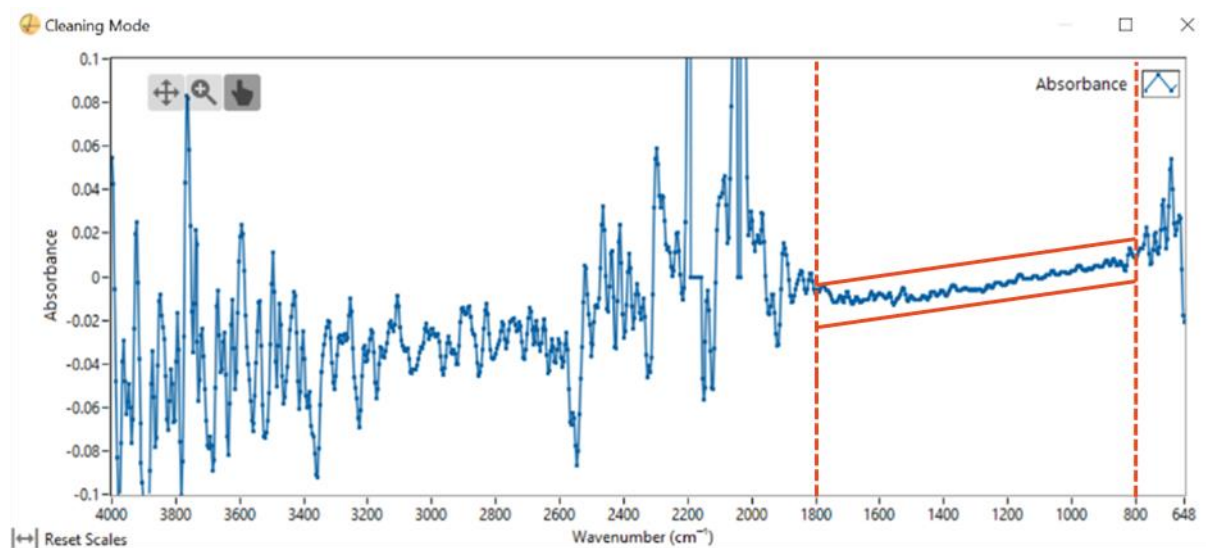

Figure 15: Probe is heated causing the spectrum to tilt

In Figure 15, the spectrum is tilted, with positive absorbance at lower wavenumbers and negative absorbance at high wavenumbers and the spectrum is not flat in the region 800-1800 cm^{-1} . This indicates that the probe tip is at a higher temperature now than it was when the background was taken. This may cause chemometric models to give incorrect results unless the model uses an appropriate pre-treatment to remove the effect. Any model built by Keit will have this taken into account.

3.2.2. Emitter ageing

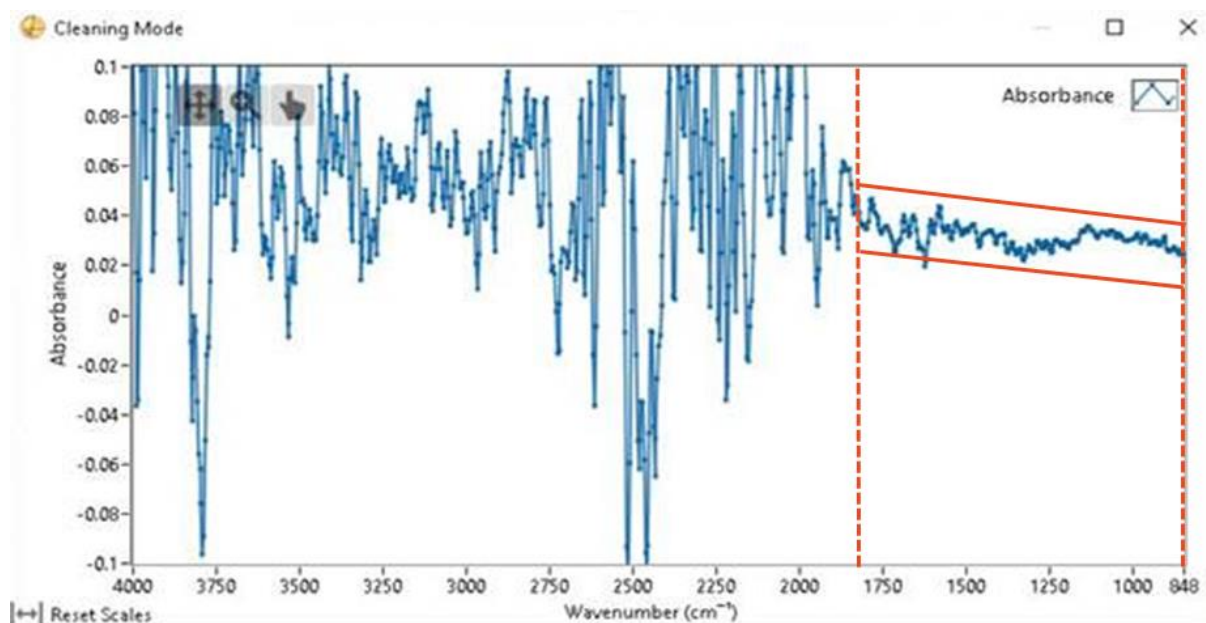

Figure 16: Spectrum is tilted showing signs of emitter ageing

The infrared emitter in the probe is expected to age over its lifetime. The results of this can be seen in Figure 16: the spectrum is tilted; the absorbance is positive across the whole spectrum; and the spectrum is not flat in the region 800-1800 cm^{-1} (contrast with Figure 9, above). If evidence of emitter ageing is seen, it may be required to take a new background scan to remove this effect – contact Keit for advice.

3.3. Remote health check

Keit can perform an annual examination of your system's health data remotely to determine if any servicing needs to be carried out. This includes review of internal diagnostics for warnings and errors, component performance for signs of premature ageing, and evaluation of background reference spectra history for signs of operator error or progressive damage.

Remote health checks are offered annually as a part of our MSP.

4. COMPONENTS

This section contains general information about the IRmadillo spectrometer, such as the constituent components and internal controller specifications.

4.0. IRmadillo spectrometer

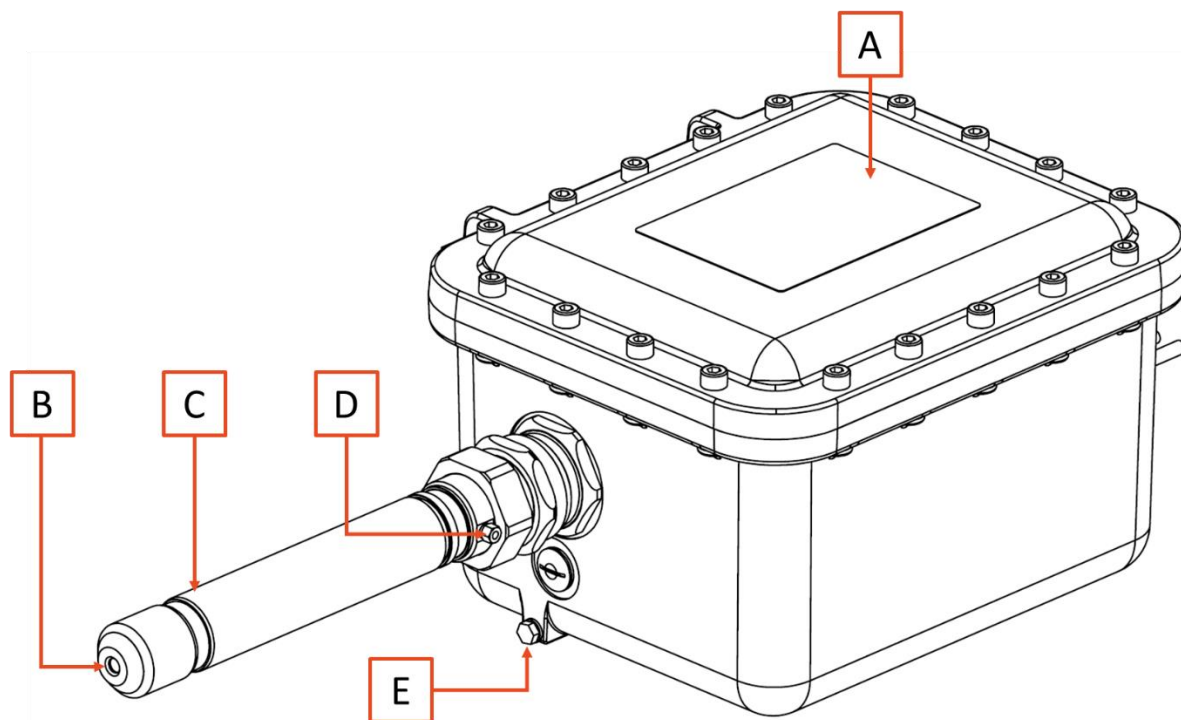

Figure 17: ASM0627-10-Z-Cx-Ex-Gx-D3x front and top of the instrument

(A) Product label

The product label specifies the model of instrument with permissible environmental and analyte operating conditions, along with applicable certification. Particular attention should be given to the rated pressure and temperature limits.

(B) ATR element

The diamond ATR element is located at the end of the probe.

(C) Probe

The probe is designed to be installed directly into a reaction vessel or pipe and is made of a corrosion-resistant metal.

(D) Probe (gas) purge outlet

Allows purge gas to escape the probe. There is a single outlet located on the probe for all purge gas to escape.

(E) Earthing point

The spectrometer body has an M6 earth attachment point below the probe. This can be used where local codes require it in addition to earthing through the power supply cable.

 WARNING	Failure to properly earth the spectrometer may cause serious injury or death.
--	--

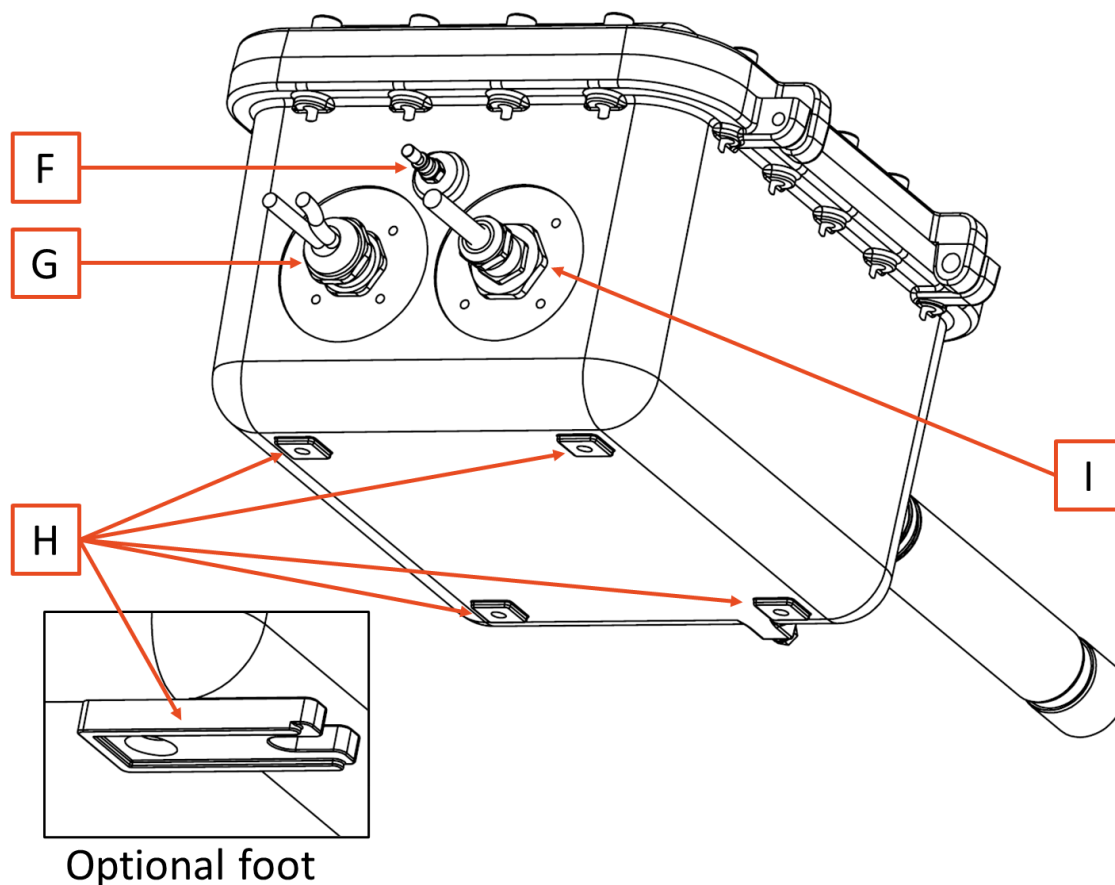

Figure 18: ASM0627-10-Z-Cx-Ex-Gx-D3x back and base of the instrument

(F) Purge inlet

The spectrometer purge inlet is used to purge both the spectrometer body and the probe at the same time through a single connection. The connection is a Legris push-fit fitting. Rigid or fixed piping may be used if the fitting is compatible and mechanical stress is avoided.

More detail on how to purge the instrument is given in Section 2.2 Purging the IRmadillo.

(G) Communication gland

This is the connection from the spectrometer for remote access, network connection or DCS. More detail on how to connect using the cables is given in Section 2.3 How to connect data communications.

(H) Mounting holes

The spectrometer must be supported using the four M8 mounting holes in its base. Optional feet are provided.

(I) Power cable gland

This is the mains power connection to the spectrometer. More detail on how to connect power to the spectrometer can be found in Section 2.1 Powering the IRmadillo.

4.0.1. Dust caps

The communication flying leads are provided with dust caps to protect the RJ45 connectors. When the cable is not in use, these should be attached to reduce the risk of potential damage to the connectors that may be caused by the local environment.

4.1. Controller specifications

Table 3 - Specifications of the IRmadillo integrated controller

Category	Specification
Integrated controller	The integrated controller has been optimised for the rugged operation of the IRmadillo spectrometer; it is not a general-purpose personal computer. Keit does not recommend the installation of additional software; changes to the configuration may affect performance and reliability.
User accounts	There are two user accounts, one with system administrator privileges and a second 'standard' user. The standard user account starts automatically and is the default account for the KeitSpec software application. The system administrator account is provided to make changes to the operating system configuration and install additional software, if required. If providing Keit remote access to the controller, the connection should be to the 'standard' Spectrometer user account.
Windows updates	The controller is running Windows 10 IoT Enterprise LTSC with automatic updates disabled by default. The local administrator should choose when/if to update the operating system. A strategy will be required to manage updates, particularly if the controller is connected to a network.
Anti-virus	There is no anti-virus installed. The controller should only be connected to internal, protected networks. Install your preferred anti-virus if required

4.2. Storage conditions

When installed with purge and power, the IRmadillo can thermally control its internal temperatures up to the limit specified on the product label. However, if the system is to be stored before its use Keit recommends an air-conditioned environment. The environment must be non-condensing, with a relative humidity below 95%. The IRmadillo or storage container should also be out of direct sunlight.

 WARNING	Storing the IRmadillo unpowered and unpurged in unsuitable conditions can cause damage to the instrument. If in doubt, please consult with Keit
--	--

5. ACCESSORIES

5.0. Sample cell - ASM1398

The sample cell is a ~5ml vessel attached at the end of the probe for performing manual sample analysis or used as part of a probe cleaning procedure. It is fixed in place using a tri clamp that locates over the rear of the sample cell and two semicircular collars that fit around the probe; the clamp does not need to be tightened with significant force. For volatile substances it is recommended to keep the plugging cap in place during use.

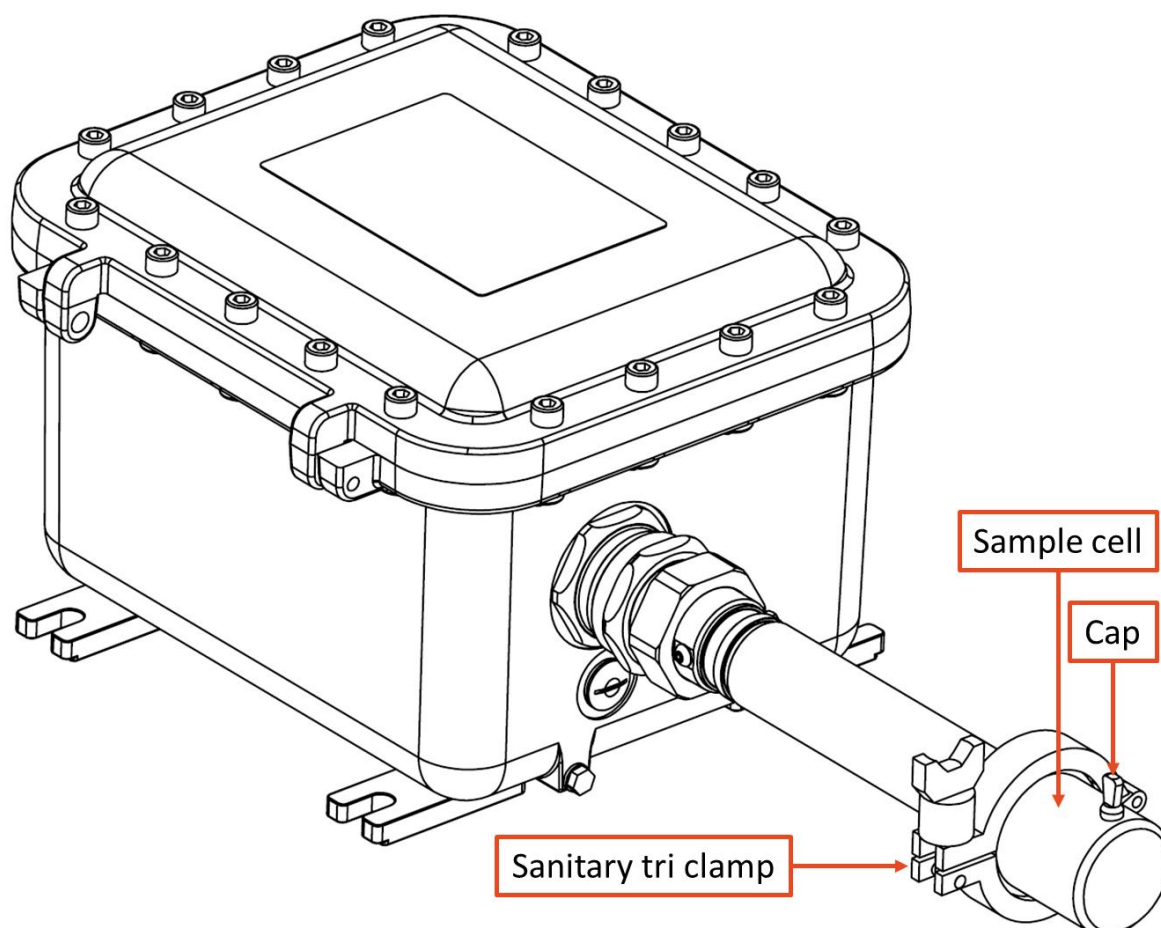

Figure 19: Sample cell fitted to IRmadillo probe

5.0.1. Maintenance

Inspect the O-ring regularly and replace if it has visually degraded, whether through swelling or other damage; use plastic forceps to remove the O-ring. This is particularly important if the chemistry that you are analysing is known to cause swelling of the O-ring elastomer. In any case, replace O-rings annually. For O-ring specifications see document “Flow cells and sample cell for ASM0627-xx-x-Cx-O-Gx-D3x (Non-ATEX Certified).pdf”

5.0.2. Cleaning

The sample cell may be cleaned using standard laboratory cleaning practices, as appropriate for your reaction. Also ensure the ATR element has been thoroughly cleaned and dried before use of the sample cell.

5.1. Flow cell

The flow cell assembly contains a pressure vessel and has been designed to withstand the analyte conditions that are specified on your product label. For detailed technical drawings, contact Keit.

5.1.1. High flow cell - ASM1392

The high flow cell is a ~27ml vessel that can be secured to the end of the probe for continuous analysis of your process. The flow cell is fitted with two $\frac{3}{4}$ " NPT ports on opposing sides, in order to accommodate a high flow rate offshoot pipe from the main process, passing the liquid in front of the ATR. This is an alternative to installing the IRmadillo into a main pipeline.

It is fixed in place using a tri clamp that locates over the rear of the flow cell and two semi-circular collars that fit around the probe; the clamp does not need to be tightened with significant force, we recommend to tighten the thumbscrew until resistance is felt + 1 turn. The flow cell can be rotated through 360° to accommodate the user's installation. Please ensure that the flow through the cell is turbulent.

Maintenance and inspection method: Visually check that all O-rings inside the cell have not perished. They should show no signs of swelling, tearing, or degradation. Also inspects the clamp and C-pieces for any signs of degradation, cracks, or damage. If the clamp and/or the C-pieces show signs of significant wear, do not re-fit them. Contact support@keit.co.uk for advice.

Do not use impact (e.g. a hammer) to separate components if the flow cell becomes stuck in the probe.

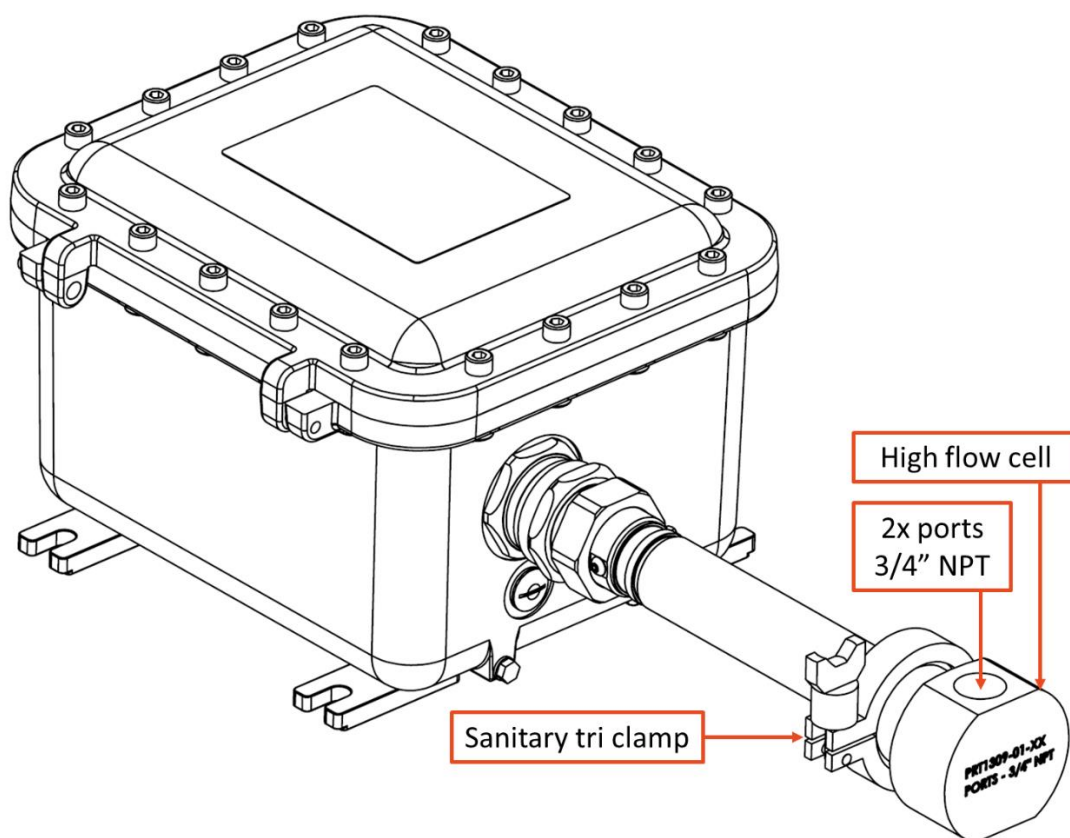

Figure 20: High flow cell fitted to IRmadillo probe

Table 4 – Specifications and safety limits (high flow cell)

Parameter	High Flow Cell
Pressure	Refer to high flow cell marking
Analyte Temperature	Refer to high flow cell marking
Body Material	Corrosion-resistant metal
O-ring Seal	FFKM (Kalrez)
Port Size	3/4" NPT
Cell Internal Volume	~27 ml
Intended Use	For use with ASM0627-10-Z-Cx-Ex-Gx-D3x
Fluid Group	1
Minimum Inspection Frequency	Annual

5.1.2. Low flow cell - ASM1222

The low flow cell is a ~0.8ml vessel that can be secured to the end of the probe for continuous analysis of your process. The flow cell is fitted with two ¼" NPT ports on opposing sides, for attaching pipelines. It is designed to force liquid past the ATR and is primarily used for lab work where flow rate and volume are low.

It is fixed in place using a tri clamp that locates over the rear of the flow cell and two semi-circular collars that fit around the probe; the clamp does not need to be tightened with significant force, we recommend to tighten the thumbscrew until resistance is felt + 1 turn. The flow cell can be rotated through 360° to accommodate the user's installation. Please ensure the flow through the cell is turbulent.

Maintenance and inspection method: Visually check that all O-rings inside the cell have not perished. They should show no signs of swelling, tearing, or degradation. Also inspects the clamp and C-pieces for any signs of degradation, cracks, or damage. If the clamp and/or the C-pieces shows signs of significant wear, do not re-fit them. Contact support@keit.co.uk for advice Please ensure that the flow through the cell is turbulent. For O-ring specifications see document "Flow cells and sample cell for ASM0627-xx-x-Cx-O-Gx-D3x (Non-ATEX Certified).pdf"

Do not use impact (e.g. a hammer) to separate components if the flow cell becomes stuck in the probe.

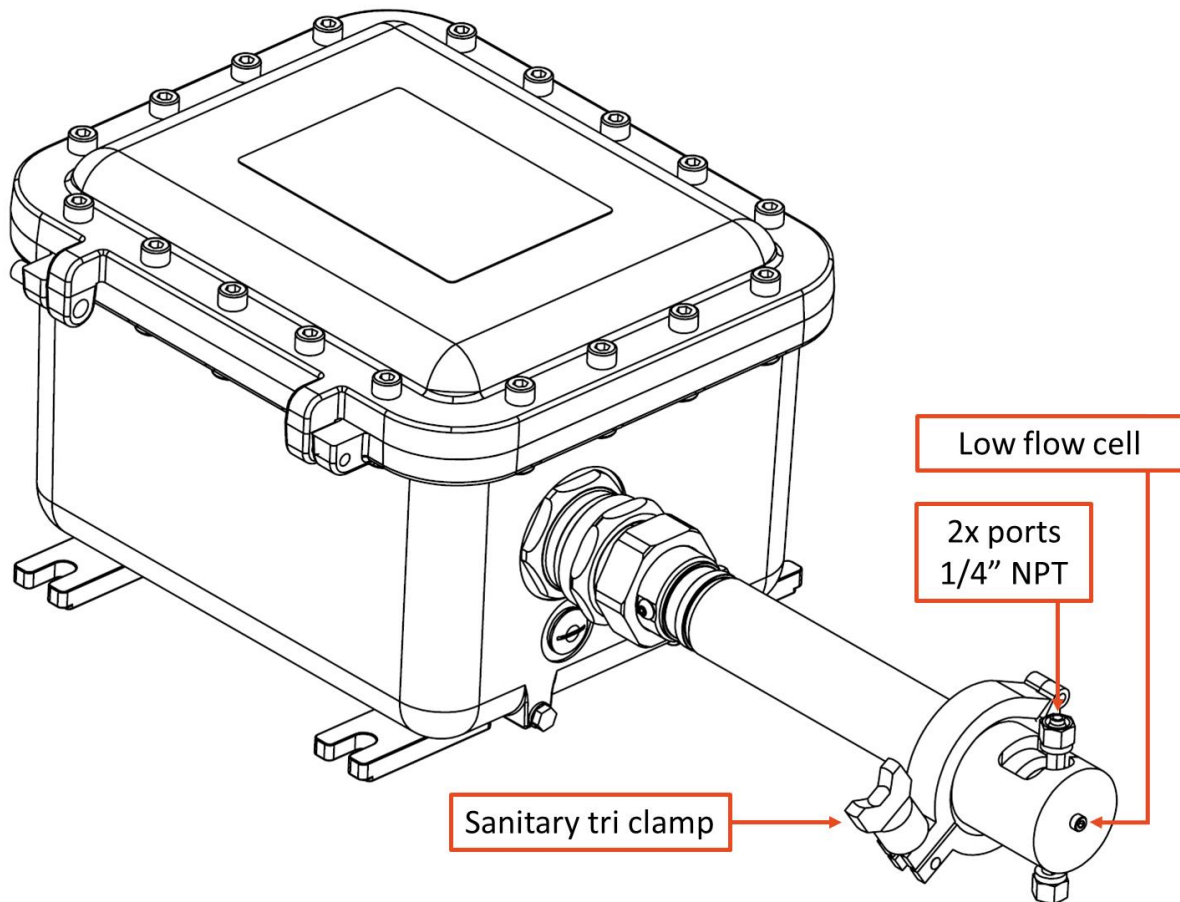

Figure 21: Low flow cell fitted to IRmadillo probe

Table 5 - Specifications and safety limits (low flow cell)

Parameter	Low Flow Cell
Pressure	Refer to low flow cell marking
Analyte Temperature	Refer to low flow cell marking
Body Material	Corrosion-resistant metal
O-ring Seal	FFKM (Kalrez)
Port Size	1/4" tubing
Cell Internal Volume	~0.8 ml
Intended Use	For use with ASM0627-10-Z-Cx-Ex-Gx-D3x
Fluid Group	1
Minimum Inspection Frequency	Annual

5.1.3. Tri-port flow cell - ASM1101

The tri-port flow cell is a ~1.5ml vessel that can be secured to the end of the probe for continuous analysis of your process. The flow cell is fitted with three 1/4" NPT ports, allowing liquid to be passed by the ATR with an additional port for a sensor or other equipment to monitor the liquid. This is primarily used for lab work where flow rate and volume are low.

It is fixed in place two collars that locate into a groove on the probe at the rear of the flow cell, these are held in place by two screws. The flow cell can be rotated through 360° to accommodate the user's installation.

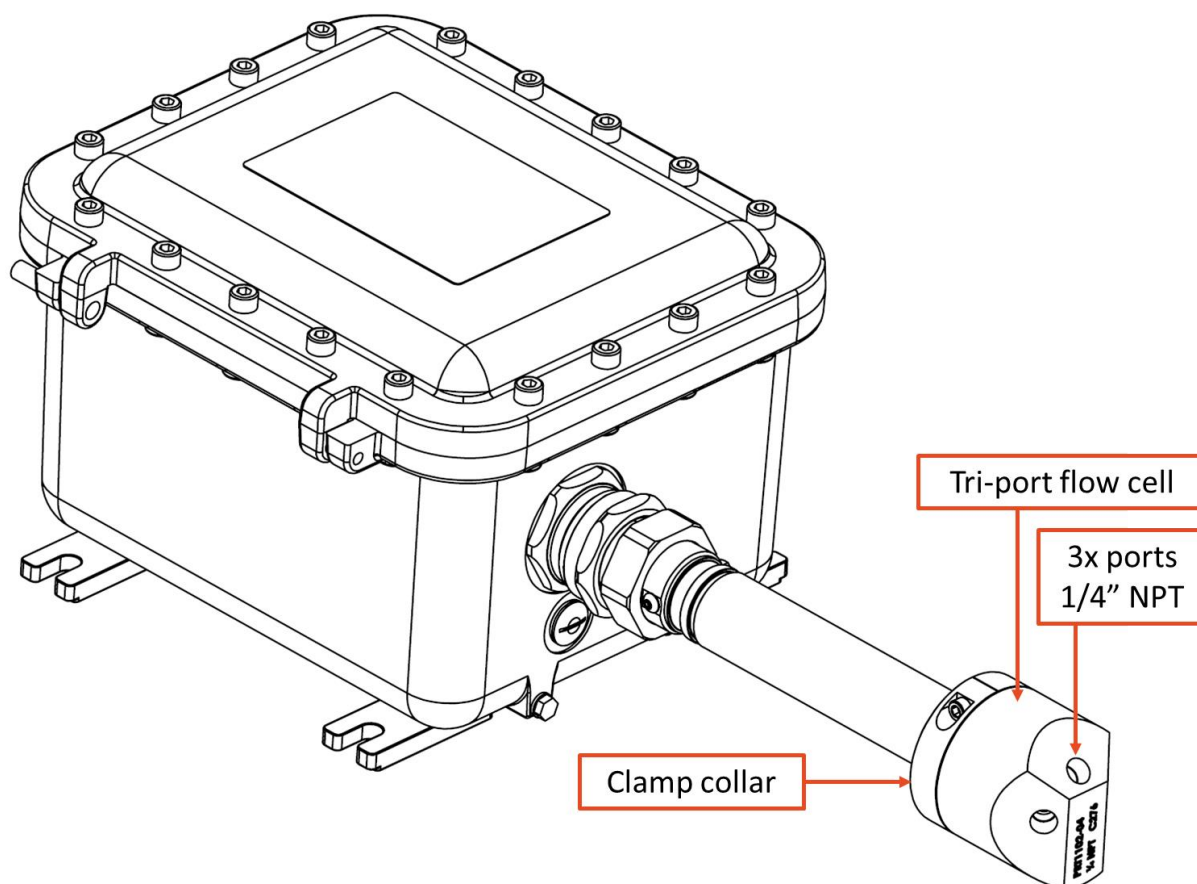









Figure 22: Tri-port flow cell fitted to IRmadillo probe

Table 6 - Specifications and safety limits (tri-port flow cell)

Parameter	Tri-Port Flow Cell
Pressure	Refer to IRmadillo product label
Analyte Temperature	Refer to IRmadillo product label
Body Material	Corrosion-resistant metal
O-ring Seal	FFKM (Kalrez)

Parameter	Tri-Port Flow Cell
Port Size	1/4" NPT
Cell Internal Volume	~1.5 ml

5.1.4. Safety

 WARNING	The flow cell assembly contains a pressure vessel.
 WARNING	Do not exceed the pressure / temperature ratings stated on the IRmadillo label.
 WARNING	Visually inspect the assembly for signs of wear and tear before use.
 WARNING	Ensure that the flow cell is depressurised before disassembly.
 WARNING	The flow cell parts will reach the same temperature as the analyte.
 WARNING	Fit protective devices to your analyte flow circuit to prevent pressure spikes that exceed the permissible values.
 CAUTION	The flow cell has restricted passages so liquids with suspended particles may cause blockages. Excessive flow rates may cause cavitation and erosion; consult with Keit if in doubt.
 CAUTION	Ensure that the NPT fittings are attached prior to final assembly; this avoids any side loads on the IRmadillo spectrometer which may cause damage.

Prevent load being applied to the instrument by the installation. Connections must not apply forces to the flow cell or the IRmadillo probe. Such loads increase the likelihood of leakage and could cause the spectral performance of the instrument to become inconsistent.

5.1.5. Maintenance

Inspect the O-ring regularly and replace if it appears to have degraded; use plastic forceps to remove the O-ring. This is particularly important if the chemistry that you are flowing through the probe is known to cause swelling of the O-ring elastomer, or if the flow cell is often removed to facilitate cleaning. For O-ring specifications see document "Flow cells and sample cell for ASM0627-xx-x-Cx-O-Gx-D3x (Non-ATEX Certified).pdf"

Inspect for signs of erosion caused by particulates in the analyte or by excessive flow velocities. If in doubt, consult with Keit.

Regularly check fastener tightness using a calibrated torque wrench.

5.1.6. Cleaning

The flow cell may be cleaned using standard laboratory cleaning practices as appropriate for your reaction. Inspect parts regularly for corrosion and damage. Replace O-rings annually.

The entire flow cell assembly, including the O-ring and fasteners, are also compatible with standard autoclave procedures.

5.2. Flanged probe

A version of the IRmadillo spectrometer probe is available to allow connection to process pipework with an ANSI/ASME B16.5 (other options available on request) compliant flange. A hub is welded to the wall of the probe and a compatible lap-joint flange is mounted between the hub and spectrometer body to permit clamping to process pipework. For technical drawings, contact Keit at enquiries@keit.co.uk.

It is important to follow these instructions completely to ensure safe use of the flanged probe.

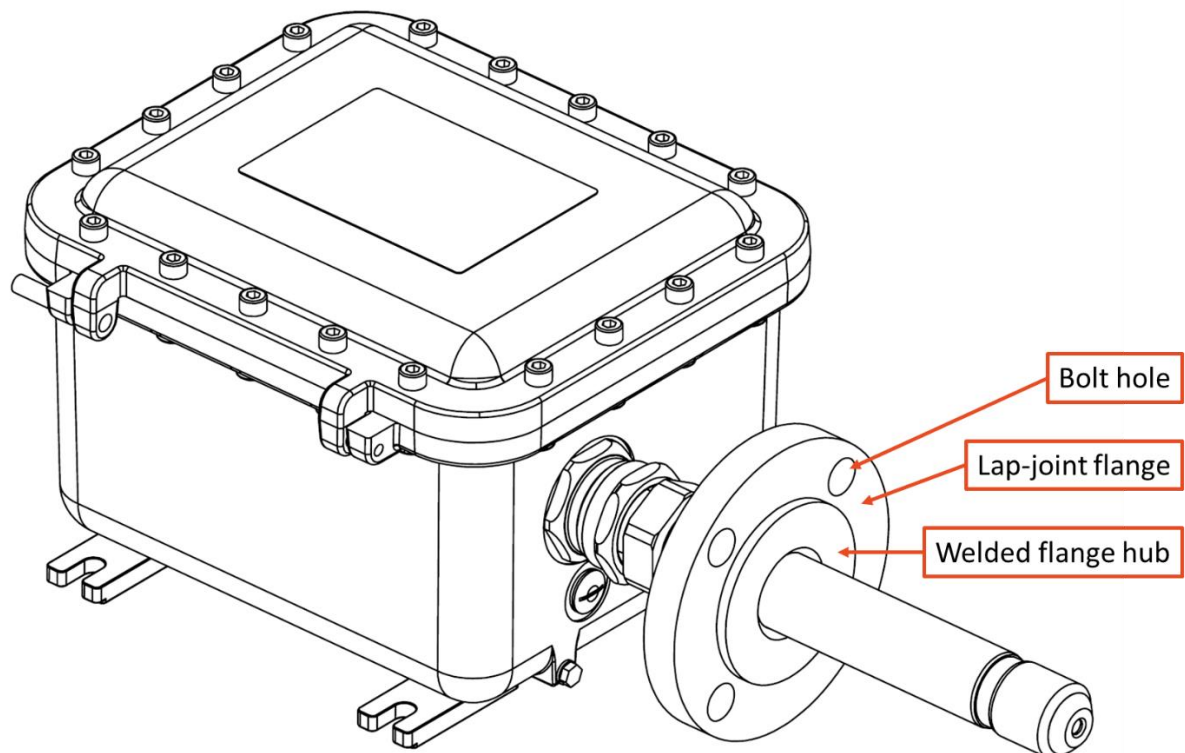



Figure 23: IRmadillo with a welded flange probe

5.2.1. Safety

 WARNING	<p>The flange and hub form a seal with the process pipework and as such are safety critical to prevent an accidental discharge of the process media. Keit recommends regular inspection of the integrity of the welds on the front and rear in line with local safety procedures.</p>
 CAUTION	<p>The spectrometer weighs ~18kg. The flange must not be used to support the instrument on process pipework. Doing so risks damage to the spectrometer and excess stress on the piping system.</p>

 WARNING	Pipe flanges' permitted working pressures are temperature dependent in accordance with the relevant standard (ANSI/ASME B16.5 or EN 1092-1).
--	---

Table 7 - Specifications and safety limits (welded flange probe)

Parameter	Welded Flange Probe
Pressure	This is limited by the ASME B16.5-2020 Pipe Flanges and Flanged Fittings Standard. Pressure derated with temperature.
Analyte Temperature	Refer to IRmadillo product label
Probe Body Material	Hastelloy C276
Welded-Hub Material	Hastelloy C276
Lap-Joint Flange Material	Hastelloy C276 or stainless steel
Gasket Material	Customer supplied. Material must be to specification of standard ANSI B16.21 or EN equivalent
Port Size	Nominal pipe size: 2 inches

5.2.2. Installation

The sealing face on the probe requires a gasket to mate against the flange on the process pipework. The gasket material must be chosen to be compatible with the pressure and temperature range of the process media and must be chemically compatible.

 WARNING	Choice of gasket material must be appropriate for the chemistry and process being used.
--	--

The probe body and hub are manufactured from Hastelloy as standard, which is resistant to many aggressive chemicals. **However, you are advised to check with Keit before installing on a new process.**

Before beginning installation, ensure that the gasket is in good condition and that the sealing faces are not scratched or dented.

Support the spectrometer on a suitable mounting frame that aligns the probe with the flange port that it will be fitted to. Avoid applying stress to the probe, weld, or flange by ensuring that the sealing face of the hub sits flush against the gasket and sealing face of the mating flange before fitting any mounting bolts to the flange.

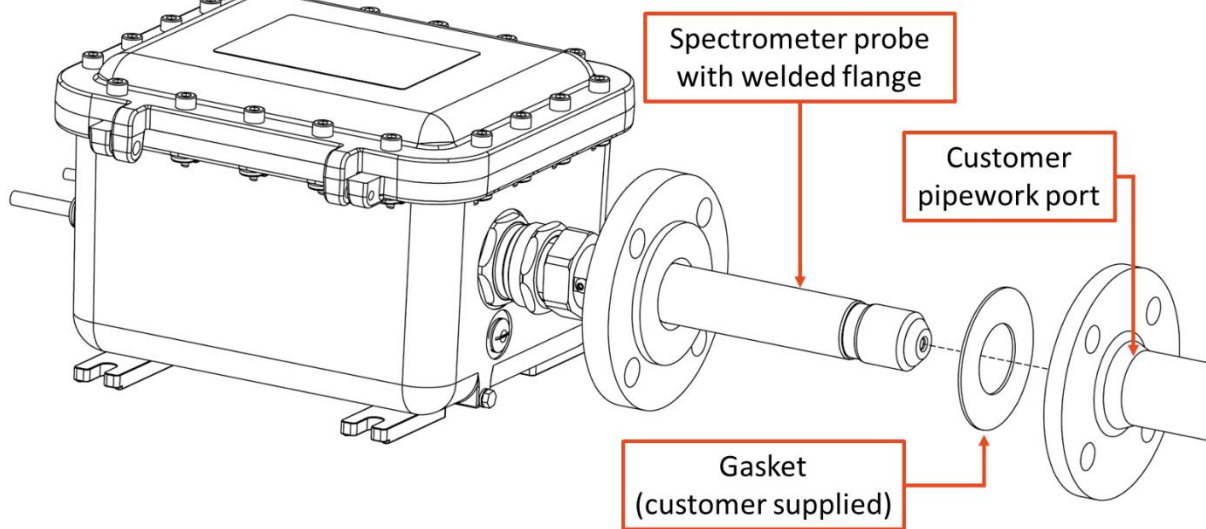

Figure 24: Fitting a flanged probe to process pipework

Once the spectrometer is aligned with the port, fit appropriate bolts as specified in the relevant standard, and tighten in stages in the order shown below.

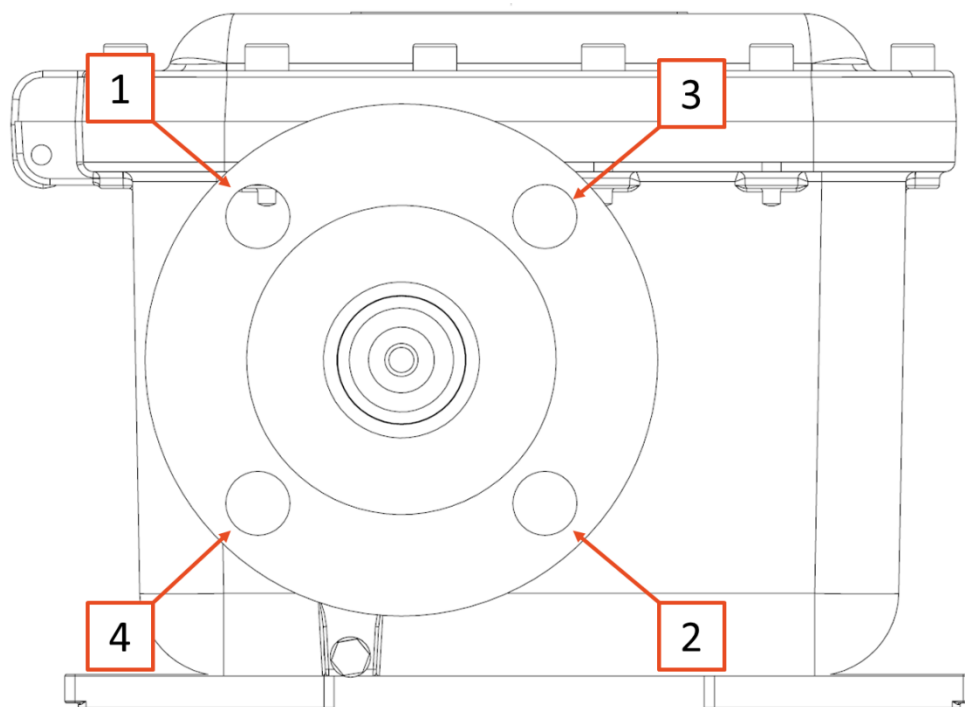

Figure 25: Front view of lap-joint flange, hub and bolt holes. Tighten bolts in steps in order 1-2-3-4 to ensure even compression of the gasket

Ensure that the bolts are sufficiently tight to prevent a leak from your pipework.

5.2.3. Maintenance

Keit recommends regular inspection of the integrity of the welds on the front and rear in line with local safety procedures.

Inspection of the sealing weld will require removal of the flange and spectrometer from the pressure vessel and can be completed as part of regular inspection/maintenance of the spectrometer and pipework.

Do not use impact (e.g. a hammer) to separate components if the gasket becomes stuck to the flange and hub.

The lap-joint flange may be manufactured from Hastelloy or stainless steel. Care should be exercised to ensure that it is not corroded by aggressive chemicals during maintenance or installation.

5.3. Port tube - ASM1487

The port tube is an accessory that can be secured to the base of the probe. This is designed for installation into pipelines for continuous analysis of your process. The port tube has two positions to weld onto either the pipe or a flange.

It is fixed in place using a tri clamp that locates over the rear of the port tube and two semi-circular collars that fit around the probe; the clamp does not need to be tightened with significant force. A blanking plug is also provided to seal the end if the spectrometer is withdrawn from the pipeline. For technical drawings, contact Keit at enquiries@keit.co.uk.

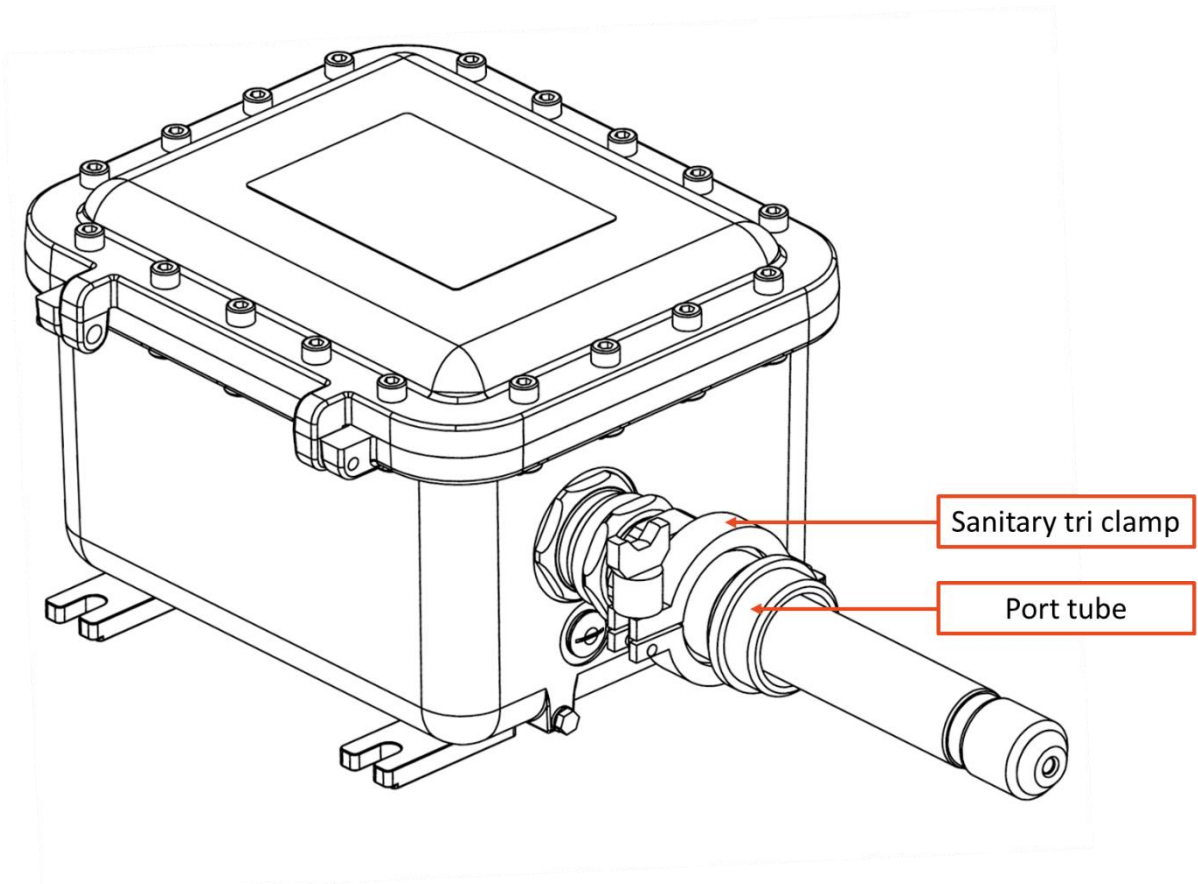



Figure 26: Spectrometer with port tube fitted

5.3.1. Safety

 WARNING	The port tube forms a seal with the process pipework and as such are safety critical to prevent an accidental discharge of the process media. Keit recommends regular inspection of the integrity of the welds in line with local safety procedures.
 CAUTION	The spectrometer weighs ~18kg. The port tube must not be used to support the instrument on process pipework. Doing so risks damage to the spectrometer and excess stress on the piping system.

Parameter	Port tube
Pressure	Refer to IRmadillo product label
Analyte Temperature	Refer to IRmadillo product label
Probe Body Material	Hastelloy C276
Port Size	Nominal pipe size: 2 inches

5.3.2. Installation

After mounting the port tube using the welding points directly to the pipeline, the probe is inserted through the port tube, sealed using an O-ring in the narrower O-ring groove.

If the IRmadillo is not going to be installed into the pipe immediately the blanking plug can be positioned with the grooved side aligning with the rear of the port tube. This is held in place using the sanitary tri clamp.

Support the spectrometer on a suitable mounting frame that aligns the probe with the flange port that it will be fitted to. The probe is inserted through the port tube; it must have a O-ring positioned in front of the clamping groove to seal.

5.4. Port Flange - ASM1486

The flanged version of the port tube accessory allows connection to process pipework with an ANSI/ASME B16.5 or EN 1092-1 compliant flange for continuous analysis of your process.

It is fixed in place using a tri clamp that locates over the rear of the port tube and two semi-circular collars that fit around the probe; the clamp does not need to be tightened with significant force. A blanking plug is also provided to seal the end if the spectrometer is withdrawn from the pipeline. For technical drawings, contact Keit at enquiries@keit.co.uk.

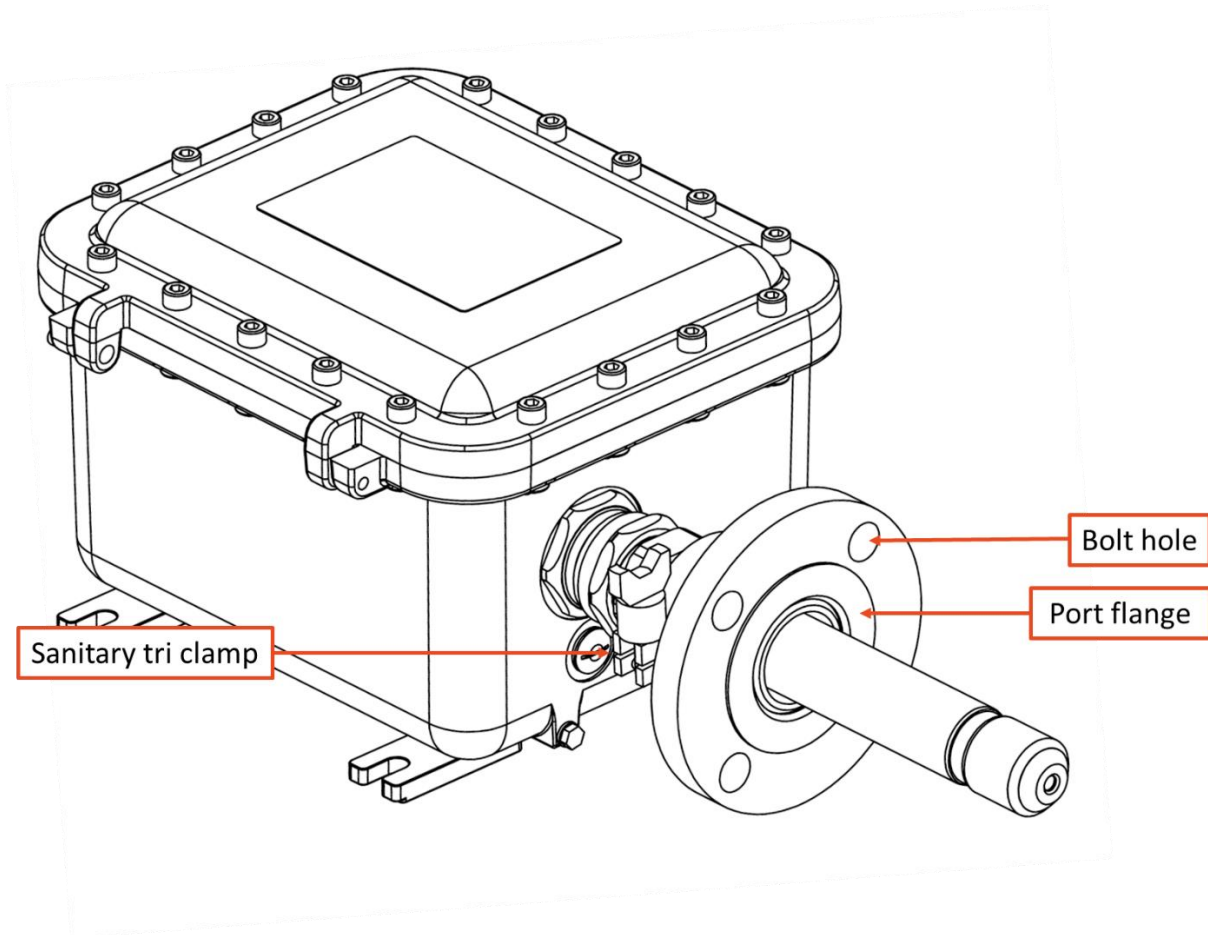





Figure 27: Spectrometer with port flange fitted

5.4.1. Safety

 WARNING	<p>The flange and hub form a seal with the process pipework and as such are safety critical to prevent an accidental discharge of the process media. Keit recommends regular inspection of the integrity of the welds on the front and rear in line with local safety procedures.</p>
 CAUTION	<p>The spectrometer weighs ~18kg. The flange must not be used to support the instrument on process pipework. Doing so risks damage to the spectrometer and excess stress on the piping system.</p>
 WARNING	<p>Pipe flanges' permitted working pressures are temperature dependent in accordance with the relevant standard (ANSI/ASME B16.5 or EN 1092-1).</p>

Parameter	Port flange
Pressure	Limited by the ASME B16.5-2020 Pipe Flanges and Flanged Fittings standard. Pressure derated with temperature
Analyte Temperature	Refer to IRmadillo product label
Probe Body Material	Hastelloy C276
Port flange Material	Hastelloy C276
Gasket Material	Customer supplied. Material must be to specification of standard ANSI B16.21 or EN equivalent
Port Size	Nominal pipe size: 2 inches

5.4.2. Installation

The sealing face on the probe requires a gasket to mate against the flange on the process pipework. The gasket material must be chosen to be compatible with the pressure and temperature range of the process media and must be chemically compatible.

	WARNING	Choice of gasket material must be appropriate for the chemistry and process being used.
---	----------------	--

The probe body and hub are manufactured from Hastelloy, which is resistant to many aggressive chemicals. **However, you are advised to check with Keit before installing on a new process.**

Before beginning installation, ensure that the gasket is in good condition and that the sealing faces are not scratched or dented.

If the IRmadillo is not going to be installed into the pipe immediately, the blanking plug can be positioned with the groove aligning with the rear of the port tube and held in place using the sanitary tri clamp.

Support the spectrometer on a suitable mounting frame that aligns the probe with the flange port to which it will be fitted. The probe is inserted through the port tube; it must have a O-ring positioned in front of the clamping groove to seal.

Avoid applying stress to the probe or flange by ensuring that the sealing face of the hub sits flush against the gasket and sealing face of the mating flange before fitting any mounting bolts to the flange.

5.4.3. Maintenance

Keit recommends regular inspection of the integrity of the welds on the front and rear in line with local safety procedures.

Inspection of the sealing weld will require removal of the flange and spectrometer from the pressure vessel and can be completed as part of regular inspection/maintenance of the spectrometer and pipework.

Do not use impact (e.g. a hammer) to separate components if the gasket becomes stuck to the flange and hub.

The lap-joint flange may be manufactured from Hastelloy or stainless steel. Care should be exercised to ensure that it is not corroded by aggressive chemicals during maintenance or installation.

Inspect the O-ring regularly and replace if it has visually degraded, whether through swelling or other damage; use plastic forceps to remove the O-ring. This is particularly important if the chemistry that you are analysing is known to cause swelling of the O-ring elastomer. In any case, replace O-rings annually. For O-ring specifications see document “Flow cells and sample cell for ASM0627-xx-x-Cx-O-Gx-D3x (Non-ATEX Certified).pdf”

5.5. Cradle - ASM1453

A mounting system for the IRmadillo spectrometer is available to simplify the installation process. The cradle allows for easy installation of the spectrometer into a pipeline with bolting positions for lap joint flange and hub complying with ASME/ANSI B16.5 or other flange options. An optional ball valve is also available.

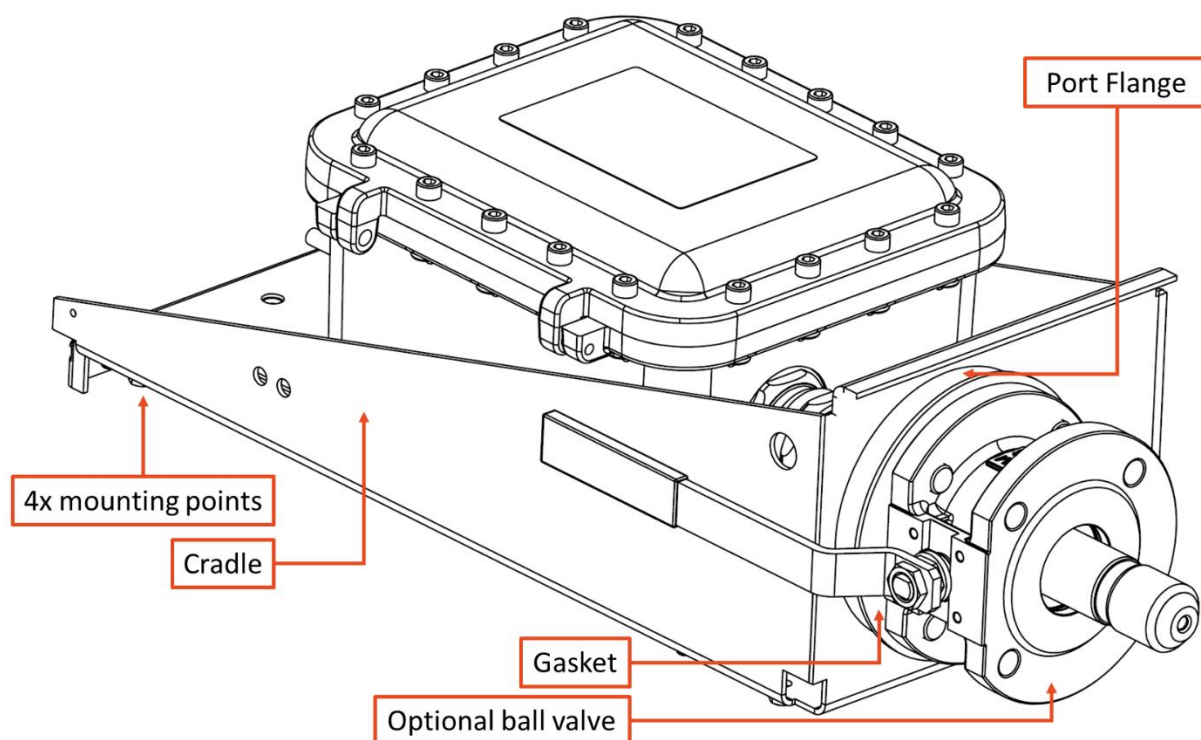

Figure 28: IRmadillo in cradle with flange and ball valve

5.5.1. Safety



 WARNING	The flange and hub form a seal with the process pipework and as such are safety critical to prevent an accidental discharge of the process media. Keit recommends regular inspection of the sealing components in line with local safety procedures.
 CAUTION	The spectrometer and cradle assembly weighs ~32.5kg. Please ensure adequate support.
 WARNING	Pipe flanges' permitted working pressures are temperature dependent in accordance with the relevant standard (ANSI/ASME B16.5 or EN 1092-1).

Table 8 - Specifications and safety limits

Parameter	Cradle
Pressure	Limited by the ASME B16.5-2020 Pipe Flanges and Flanged Fittings standard. Pressure derated with temperature
Analyte Temperature	Refer to IRmadillo product label
Probe Body Material	Hastelloy C276
port flange Material	Hastelloy C276
Gasket Material	Customer supplied. Material must be to specification of standard ANSI B16.21 or EN equivalent
Port Size	Nominal pipe size: 2 inches
Optional Ball valve	Wafer ball valve Class 150lb NPS 2 inch. Material: Stainless steel with PTFE seals.
Gasket supplied with ball valve option.	PTFE

5.5.2. Installation

The sealing face on the probe requires a gasket to mate against the flange on the process pipework. The gasket material must be chosen to be compatible with the pressure and temperature range of the process media and must be chemically compatible.

 WARNING	Choice of gasket material must be appropriate for the chemistry and process being used.
--	--

The probe body and hub are manufactured from Hastelloy, which is resistant to many aggressive chemicals; the optional ball valve is stainless steel. **You are advised to check with Keit before installing on a new process.**

Before beginning installation, ensure that the gasket is in good condition and that the sealing faces are not scratched or dented.

Support the cradle such that it aligns the probe with the flange port that it will be fitted to. Avoid applying stress to the probe, weld, or flange by ensuring that the sealing face of the hub sits flush against the gasket and sealing face of the mating flange before fitting any mounting bolts to the flange.

The cradle has lifting points to assist in locating: two either side of the cradle at the front and one located through the base plate at the back. The cradle also has 4 mounting points through the base.

5.5.3. Maintenance

Keit recommends regular inspection of the integrity of the welds on the front and rear in line with local safety procedures.

Inspection of the sealing weld will require removal of the flange and spectrometer from the pressure vessel and can be completed as part of regular inspection/maintenance of the spectrometer and pipework.

Do not use impact (e.g. a hammer) to separate components if the gasket becomes stuck to the flange and hub.

The lap-joint flange may be manufactured from Hastelloy or stainless steel. Care should be exercised to ensure that it is not corroded by aggressive chemicals during maintenance or installation.

5.6. Inclined Stand – ASM0916

The inclined stand is designed for using the spectrometer as a bench top instrument for offline sampling. Angled at 35°, the probe can be positioned into beakers or other vessels for ease of use. It can also be configured for two heights to give added flexibility in how it is used.

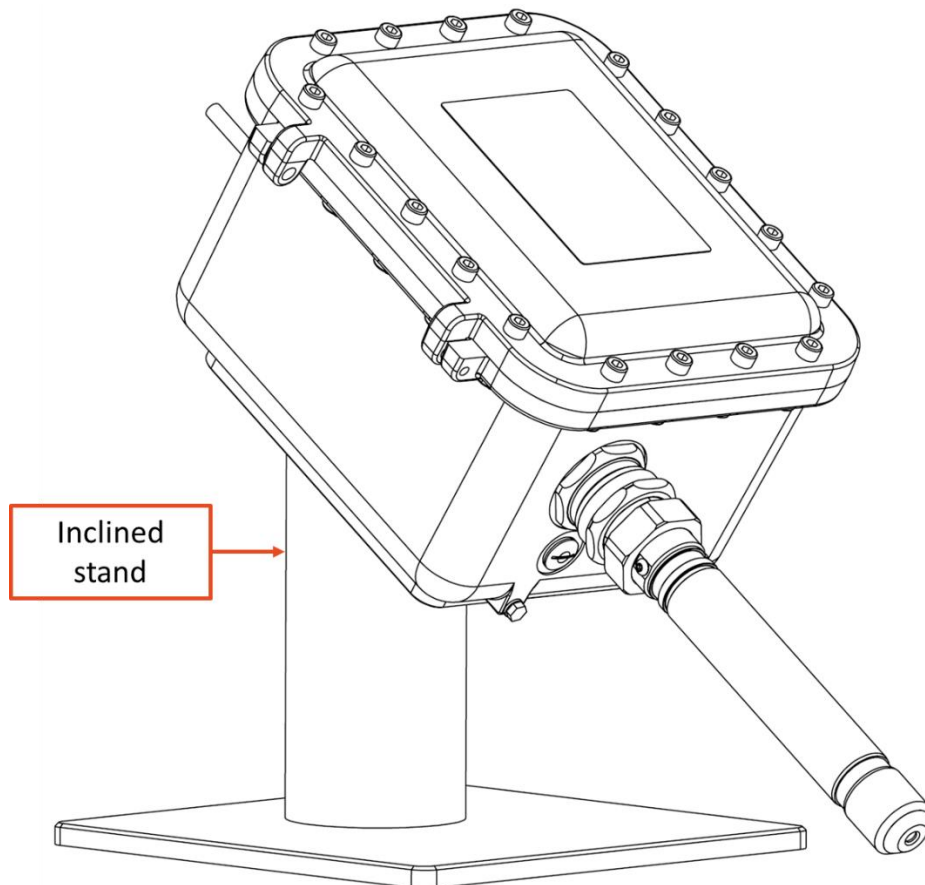



Figure 29: IRmadillo on an inclined stand

5.6.1. Safety

 WARNING	The spectrometer and inclined stand assembly weighs ~24kg. Use caution when handling to avoid injury.
--	--

5.6.2. Installation

Assemble the inclined stand to the desired height; two positions are possible. For technical drawings, contact Keit at enquiries@keit.co.uk.

To install the inclined stand to the instrument, carefully roll the spectrometer over such that the mounting holes are pointed upward, the instrument should be disconnected from power coms and purge to avoid damage to the cables or twisting.

Position the inclined stand over the mounting points such that the mounting plate lines up with the instrument. The spectrometer is located with 4 screws through the corners of the stand into the mounting holes on the spectrometer.

Return the instrument to the correct orientation and connect the purge, the power cable, and communications cable/s.

5.7. Ingold DN40

A version of the IRmadillo spectrometer probe is available to allow connection to reaction vessels or process pipework fitter with an Ingold DN40 port. The probe tube is fitted with a Ingold DN40 nut that can be fitted to compatible ports. For technical drawings, contact Keit.

It is important to follow these instructions completely to ensure safe use of the Ingold probe.

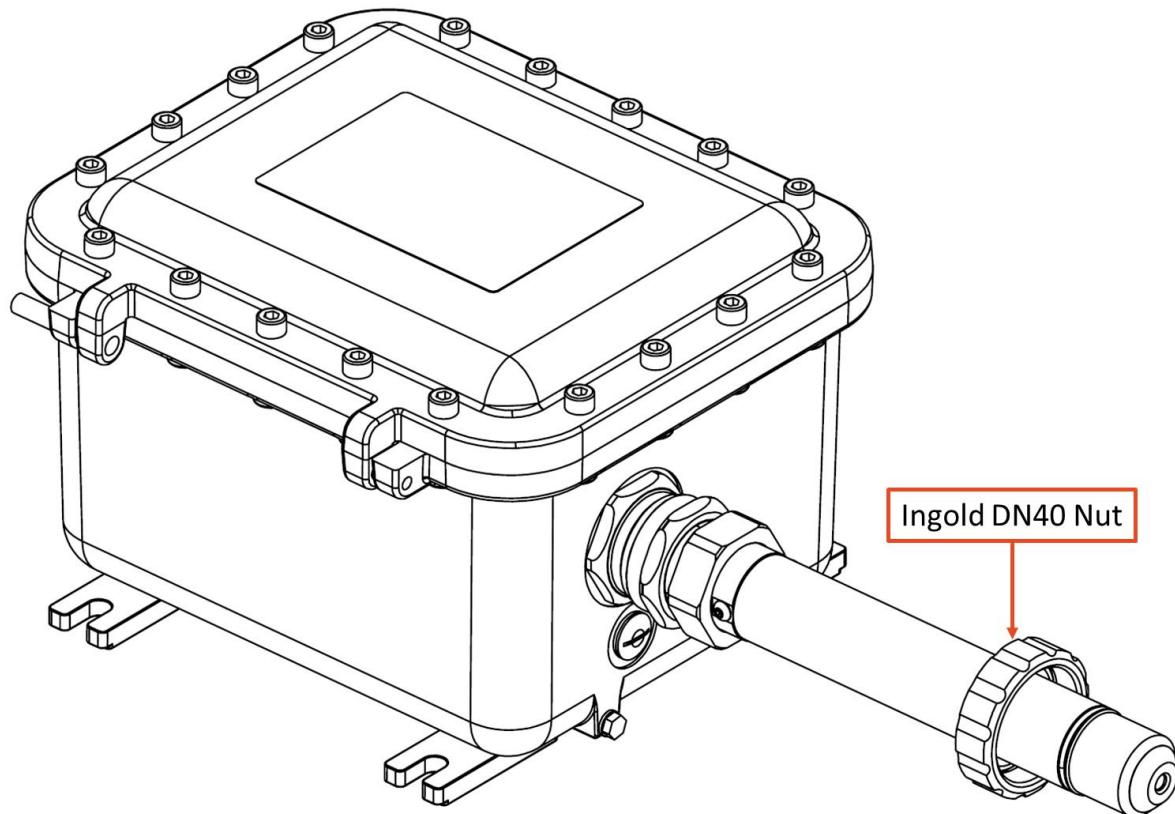

Figure 30: IRmadillo fitted with an Ingold probe

5.7.1. Safety



 WARNING	<p>The O-ring and nut form a seal with the process pipework and as such are safety critical to prevent an accidental discharge of the process media. Keit recommends regular inspection of the port in line with local safety procedures.</p>
 CAUTION	<p>The spectrometer weighs ~18kg. The probe must not be used to support the instrument on process pipework. Doing so risks excess stress on the piping system.</p>

Table 9 - Specifications and safety limits for the Ingold probe

Parameter	Ingold Probe
Pressure	Refer to IRmadillo product label
Analyte Temperature	Refer to IRmadillo product label
Probe Body Material	Hastelloy C276
Port Size	DN40 Ingold port
Port Material	1.4435 acc. to BN2 and 316L acc. to ASME BPE table DT3

5.7.2. Installation

Support the spectrometer on a suitable mounting frame that aligns the probe with the flange port that it will be fitted to. Avoid applying stress to the probe by ensuring that the nut and threaded section of the Ingold port align before tightening or bolting the spectrometer in place.

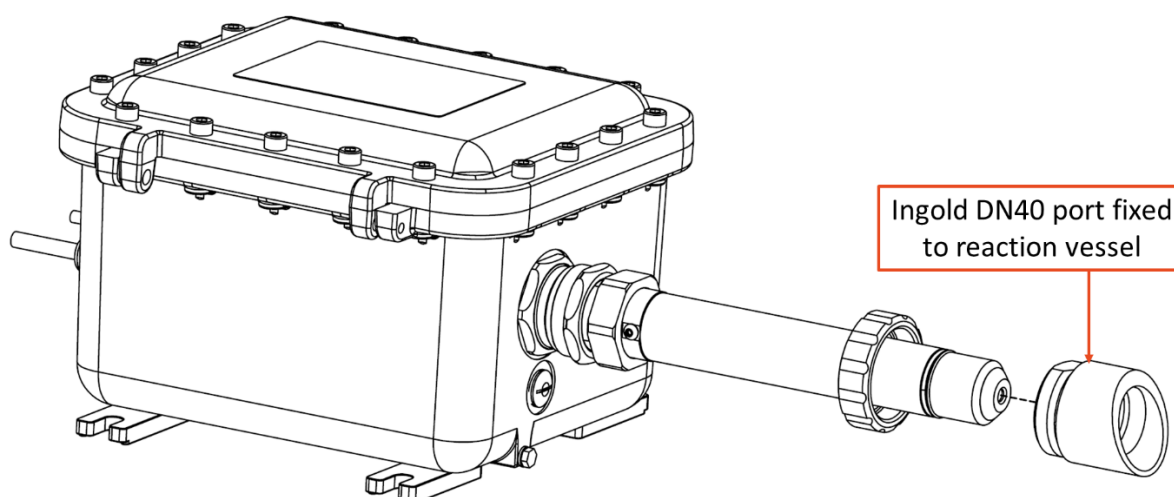
Figure 31: Fitting an Ingold IRmadillo probe into an Ingold Port

6. TROUBLESHOOTING

If you encounter any issues either during installation or during use of the IRmadillo please contact Keit (support@keit.co.uk).

Below are some examples of issues that may be experienced with potential solutions to the problem.

Table 10 – Troubleshooting guide

Issue	Cause	Potential Solution
Modbus communications appear unresponsive despite the spectrometer running normally	Some third-party Modbus clients can crash the USB subsystem on the client PC, causing a loss of connection	Restart the USB COM port on the remote computer. The Modbus client should be designed to recover from a null response and have a finite timeout period.
Insensitive to analyte changes	ATR element not in sample	Ensure ATR element is properly immersed in sample to be analysed
Noise in spectra that doesn't disappear with longer sampling times	Background scan taken with insufficient averaging	Experiment with increased background scan acquisition time
Negative peaks in spectrum	Background scan taken with a dirty probe	Clean ATR element and take a new background scan.
Signal too noisy	Insufficient averaging	Experiment with increased averaging
Low / No signal	Instrument warming up	Allow the instrument to warm up for several minutes before checking raw spectrum. Recommended to allow 12 hr to fully warm up before use.
	Switch on from a very low or a high temperature	Allow to warm up for 12 hr before checking raw spectrum. It will take time to stabilise the internal temperature and you must wait for this to occur.
	Thermal shutdown activated operation outside of specification.	Contact Keit for advice on resetting the instrument
Appearance of unexplained features (characteristically seen at 1600 – 1700 cm⁻¹)	Water vapour present in instrument	Check that your purge gas specification is suitable and that your gas supply is free flowing with no blockages
		Check that any purge tubing is stainless steel or PTFE.

Issue	Cause	Potential Solution
Unrepeatable measurements	Damage to ATR element	Contact Keit
	Contamination of ATR element	Clean the probe. See Section 2.4 Checking for warnings and checking the probe is clean
	Dip probe misaligned by inappropriate use	Contact Keit
	Analyte temperature changes	Some cross sensitivity is expected